



E-Line Brass SMA Connectors

ONLINE CATALOG

Contents

CLICK ON ANY LINE TO GO DIRECTLY TO THE INDICATED PAGE

Navigation Guide	2
Specifications and interface dimensions	3

Cable Connectors

Cable Plugs—Semi-Rigid Cable	4
Cable Jacks—Semi-Rigid Cable	4
Bulkhead Jacks—Semi-Rigid Cable	4
Panel Jacks—Semi-Rigid Cable.	4
Cable Plugs—Flexible Cable	5
Cable Jacks—Flexible Cable	5
Bulkhead Jacks—Flexible Cable	5

Jack Receptacles

Panel Mount—Solder Pot Contact	6
Panel Mount—Tab Contact	6
Panel Mount—Post Contact	6
Bulkhead Mount	7
P.C. Board Through Hole.	7

Plug Receptacles

Panel Mount—Solder Pot Contact	8
Panel Mount—Tab Contact	8
Panel Mount—Post Contact	8

Adapters

In-Series Adapters	9
------------------------------	---

Technical Information

Mounting Figures	10
Cable Groups.	11
Cable Assembly Instructions	12
Assembly Tooling	14
Ordering and Warranty.	15

We have configured this online catalog to take advantage of Acrobat navigation shortcuts (links). However, these links are not visible on the pages—making them visible would compromise the page’s readability.

- Clicking on any entry in the Table of Contents will take you to the indicated page.
- Shown below are the “hot spots” on all of the product pages that will take you to background information on various connector characteristics.
- After you use a link to jump to another page, you can use the “back” arrow in Acrobat’s menu bar to return to the page you jumped from.
- Configure Acrobat Reader to show bookmarks for a table of contents by specific characteristic (for example, cable plugs broken out by cable attachment method).
- To find a specific part number, use Acrobat’s search feature.

In addition, the pages are formatted to fit within the margins of standard laser or inkjet printers—no need to use the “shrink to fit” option when printing pages from Acrobat.

Click [here](#) to go to the Table of Contents

Click on the Delta logo on any page to jump to the table of contents.

Click on the page title to jump to specifications and interface dimensions.

BNC Cable Jacks

Panel Jack—Military Clamp for Flexible Cable

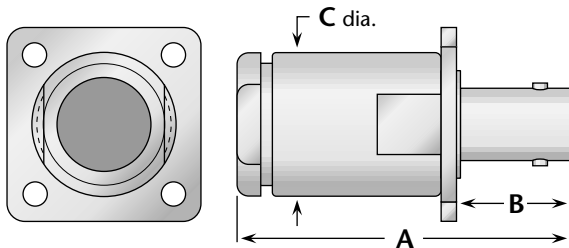

Figure 1

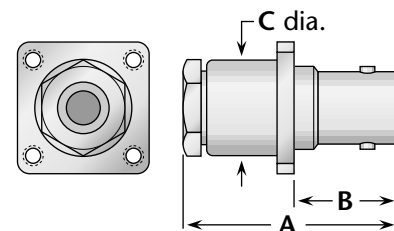

Figure 2

Cable Group	Fig.	Dimensions			Mounting Figure	Plating		Delta P/N	Assembly Procedure/Trim Code
		A	B	C		Body	Contact		
1	1	1.75	.63	.75	33	Nickel	Silver	1011-001-N330	A/20
2, 3	1	1.75	.63	.75	33	Nickel	Silver	1011-004-N330	A/20
5, 6	2	1.16	.55	.50	07	Nickel	Silver	UG-291C/U	A/17

Click here to jump to dimensions for Delta mounting figures.

Click here to jump to the cable assembly procedure for this connector.

Click here to jump to a guide to Delta cable groups.

Click here to go to Delta’s website if your computer is configured for Web connection via Acrobat.

General Description

Delta *E-Line* brass SMA connectors are subminiature, 50Ω impedance connectors with 1/4"-36 threaded coupling. Their use of brass for body parts provides lower cost while retaining electrical performance similar to that of stainless steel SMA counterparts.

If your application does not require the 500 mating cycles of service life provided by stainless steel SMA connectors, *E-Line* SMAs can fulfill your needs at a reduced cost. For additional economy, nickel-plated bodies can be specified instead of gold plating.

E-Line brass SMA connectors can be used with semi-rigid cables in applications up to 18 GHz, or miniature flexible cables up to 12.4 GHz.

Our *E-Line* brass SMA product line is still growing, so please call if you don't see what you need.

E-Line Brass SMA Specifications*

Plug Interface**

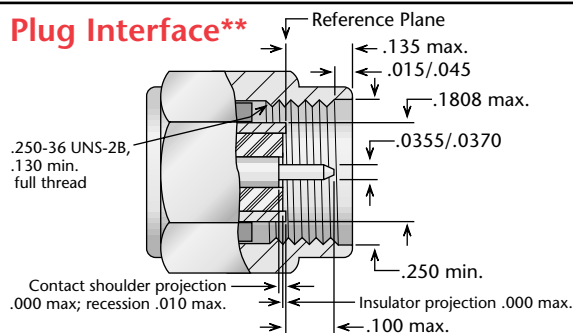

Electrical:

Nominal Impedance: 50 ohms.

Frequency Range: DC-18 GHz (with semi-rigid cable);
DC-12.4 GHz (with flexible cable).

Voltage Rating: 335-500 volts RMS (dependent on cable).

Dielectric Withstanding

Voltage: 500-1500 volts RMS (dependent on cable).

Insulation Resistance: 5,000 megohms.

Materials/Finishes:

Insulators: Teflon per ASTM D1710.

Male Contacts: Brass per ASTM B16, or
Beryllium Copper per ASTM B196.

Female Contacts: Beryllium Copper per ASTM B196.

Contact Plating: Gold per MIL-G-45204.

Gaskets: Silicone rubber per ZZ-R-765,
Class II, Grade 50.

Other Metal Parts: Brass per ASTM B16 or equivalent; gold plated per
MIL-G-45204, or nickel plated per QQ-N-290.

All other specifications are in accordance with the latest issues of MIL-PRF-39012, or MIL-A-55339, or other applicable MIL specifications, and interfaces are in accordance with MIL-STD-348.

*These specifications are typical and may not apply to all connectors. Detailed specifications for individual connectors are available on request.

Jack Interface**

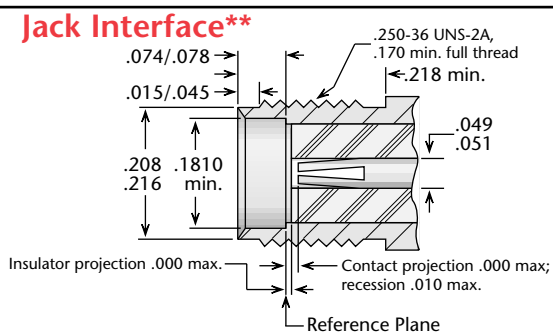

**Some proportions altered to illustrate detail.

Straight and Right Angle Plugs—For Semi-Rigid Cable

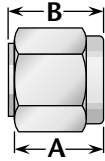

Figure 1
(Straight plug—direct solder)

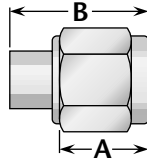

Figure 2
(Straight plug—direct solder)

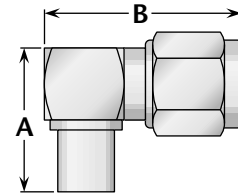

Figure 3
(Right angle plug—direct solder)

Cable Group	Figure	Dimensions		Plating		Delta P/N	Assembly Procedure/ Trim Code
		A	B	Body	Contact		
13	1	.330	.344	Gold*	None ⁽¹⁾	1301-031-G003-502	G/01
13	2	.459	.330	Gold*	None ⁽¹⁾	1301-031-G003-501	G/01
13	2	.330	.459	Gold*	Gold	1301-031-G003-500	H/03
13	3	.46	.63	Gold*	Gold (C)	1305-031-G003-500	J/02
14	2	.330	.459	Gold*	Gold	1301-025-G003-500	H/03
14	3	.46	.63	Gold*	Gold (C)	1305-025-G003-500	J/02

⁽¹⁾ Cable center conductor used as contact.

Straight, Panel and Bulkhead Jacks—For Semi-Rigid Cable

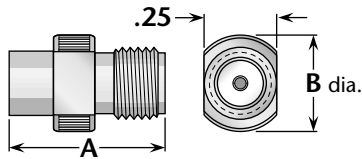

Figure 1
(Straight jack, direct solder)

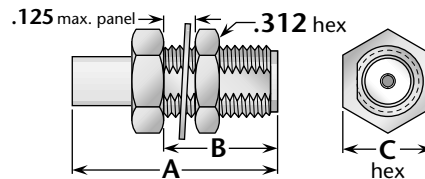

Figure 2
(Bulkhead mount, direct solder)

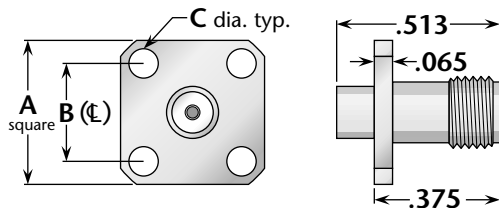

Figure 3
(4-hole flange, direct solder)

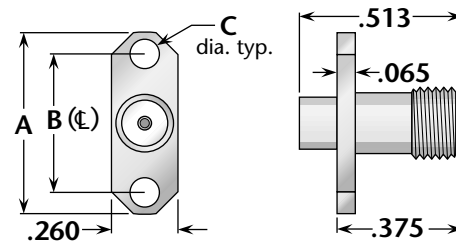

Figure 4
(2-hole flange, direct solder)

Cable Group	Fig.	Dimensions			Mounting Figure	Plating		Delta P/N	Assembly Procedure/ Trim Code
		A	B	C		Body	Contact		
13	1	.500	.335	—	—	Gold*	Gold	1308-031-G003-500	H/01
13	2	.850	.500	.312	67	Gold*	Gold	1317-031-G673-500	H/04
13	3	.500	.340	.102	05	Gold*	Gold	1311-031-G053-500	H/01
13	4	.625	.481	.102	92A	Gold*	Gold	1311-031-G923-500	H/01
14	1	.500	.335	—	—	Gold*	Gold	1308-025-G003-500	H/01
14	2	.850	.500	.312	67	Gold*	Gold	1317-025-G673-500	H/04
14	3	.500	.340	.102	05	Gold*	Gold	1311-025-G053-500	H/01
14	4	.625	.481	.102	92A	Gold*	Gold	1311-025-G923-500	H/01

* Also available with nickel-plated body—change G in Delta part number to N. • (C) in contact plating column indicates captive contact.

Straight and Right Angle Plugs—Crimp Type For Flexible Cable

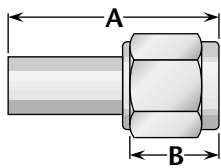

Figure 1
(Straight plug)

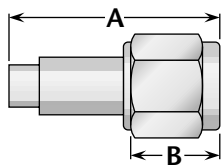

Figure 2
(Straight plug)

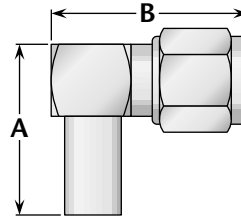

Figure 3
(Right angle plug)

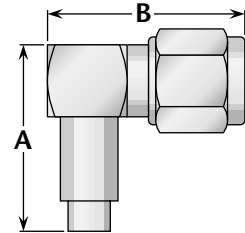

Figure 4
(Right angle plug)

Cable Group	Figure	Dimensions		Plating		Delta P/N	Assembly Procedure/ Trim Code
		A	B	Body	Contact		
5	1	.88	.330	Gold*	Gold	1303-017-G000-500	K/05
5	3	.65	.63	Gold*	Gold (C)	1307-017-G001-500	L/03
6	1	.88	.330	Gold*	Gold	1303-013-G000-500	K/05
6	3	.65	.63	Gold*	Gold (C)	1307-013-G001-500	L/03
9	1	.66	.330	Gold*	Gold	1303-037-G000-500	K/06
9	3	.65	.63	Gold*	Gold (C)	1307-037-G001-500	L/03
10	1	.66	.330	Gold*	Gold	1303-100-G000-500	K/06
10	3	.65	.63	Gold*	Gold (C)	1307-100-G001-500	L/03
11	2	.76	.330	Gold*	Gold	1303-038-G000-500	K/07
11	4	.65	.63	Gold*	Gold (C)	1307-038-G001-500	L/03

Straight and Bulkhead Jacks—Crimp Type For Flexible Cable

Figure 1
(Straight jack)

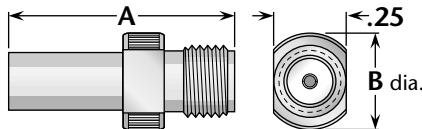

Figure 2
(Straight jack)

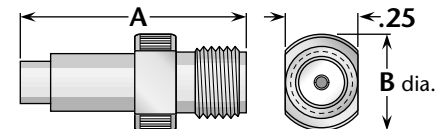

Figure 3
(Bulkhead jack)

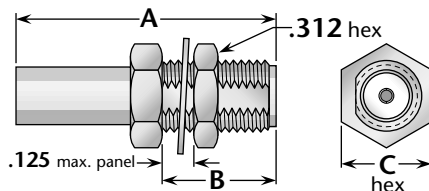
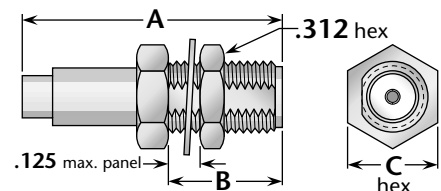

Figure 4
(Bulkhead jack)



Cable Group	Fig.	Dimensions			Mounting Figure	Plating		Delta P/N	Assembly Procedure/ Trim Code
		A	B	C		Body	Contact		
5	1	.76	.335	—	—	Gold*	Gold	1310-017-G000-500	K/08
5	3	.99	.500	.312	67	Gold*	Gold	1319-017-G670-500	K/10
6	1	.76	.335	—	—	Gold*	Gold	1310-013-G000-500	K/08
6	3	.99	.500	.312	67	Gold*	Gold	1319-013-G670-500	K/10
9	1	.74	.335	—	—	Gold*	Gold	1310-037-G000-500	K/08
9	3	.99	.500	.312	67	Gold*	Gold	1319-037-G670-500	K/10
10	1	.74	.335	—	—	Gold*	Gold	1310-100-G000-500	K/08
10	3	.99	.500	.312	67	Gold*	Gold	1319-100-G670-500	K/10
11	2	.74	.335	—	—	Gold*	Gold	1310-038-G000-500	K/09
11	4	.99	.500	.312	67	Gold*	Gold	1319-038-G670-500	K/11

* Also available with nickel-plated body—change G in Delta part number to N. • (C) in contact plating column indicates captive contact.

Panel Jack Receptacles

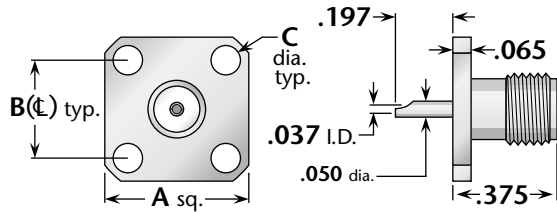

Figure 1
(Solder pot contact—square flange)

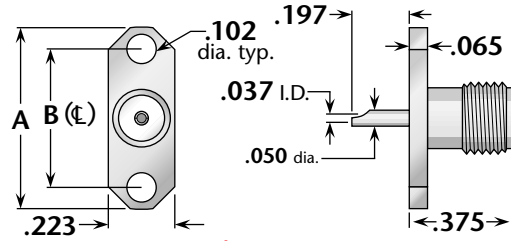

Figure 2
(Solder pot contact—2-hole flange)

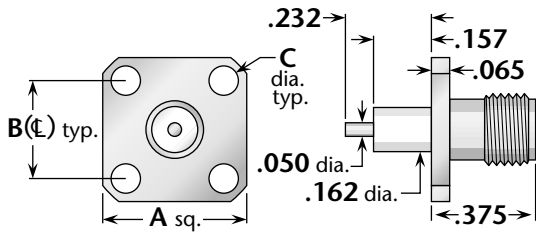

Figure 3
(Post contact—square flange)

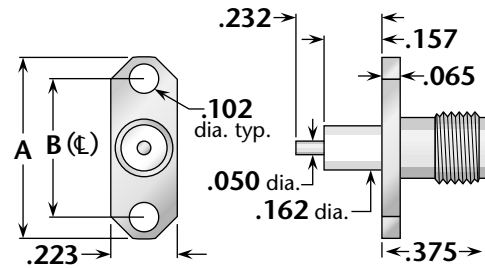

Figure 4
(Post contact—2-hole flange)

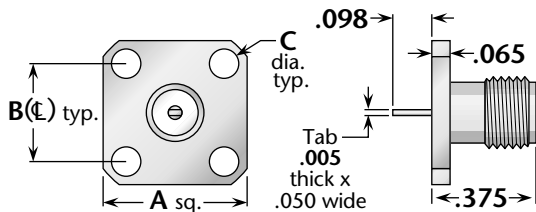

Figure 5
(Tab contact—square flange)

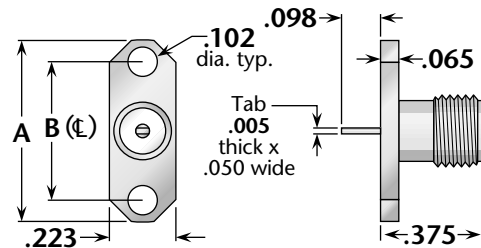

Figure 6
(Tab contact—2-hole flange)

Figure	Dimensions			Mounting Figure	Plating		Delta P/N
	A	B	C		Body	Contact	
1	.500	.340	.102	05	Gold*	Gold (C)	1313-000-G051-500
2	.625	.481	.102	92	Gold*	Gold (C)	1313-000-G921-500
3	.500	.340	.102	05	Gold*	Gold (C)	1358-000-G051-500
4	.625	.481	.102	92	Gold*	Gold (C)	1358-000-G921-500
5	.500	.340	.102	05	Gold*	Gold (C)	1358-000-G051-501
6	.625	.481	.102	92	Gold*	Gold (C)	1358-000-G921-501

* Also available with nickel-plated body—change G in Delta part number to N.
(C) in contact plating column indicates captive contact (mechanical captivation).
All items available with other flange, contact, and insulator configurations.

Bulkhead Jack Receptacles

Figure 1
(Rear mount, solder pot contact, no mounting gasket)

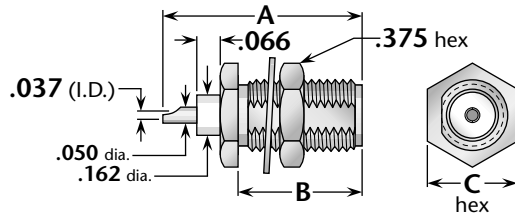

Figure 2
(Round body, post contact)

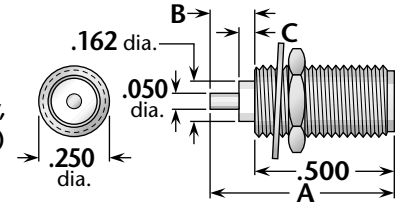

Figure	Dimensions			Max. Panel	Mounting Figure	Plating		Delta P/N
	A	B	C			Body	Contact	
1	.67	.450	.375	.125	67	Gold	Gold (C)	1321-000-G671-500
2	.66	.157	.075	.125	82	Gold	Gold (C)	1321-000-G821-500
2	.62	.118	.000	.125	82	Gold	Gold (C)	1321-000-G821-501

Printed-Circuit Board Receptacles

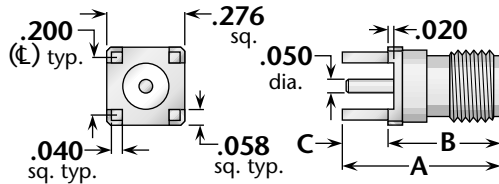

Figure 1 (Straight jack)

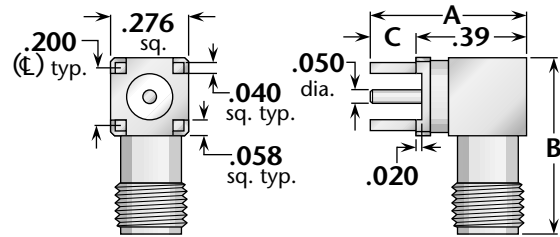

Figure 2 (Right angle jack)

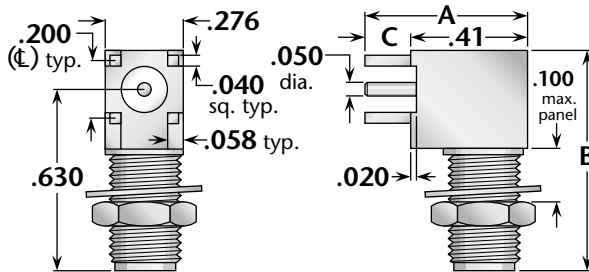

Figure 3 (Right angle bulkhead jack)

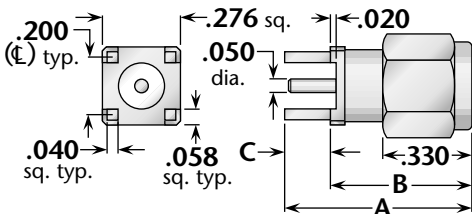

Figure 4 (Straight plug)

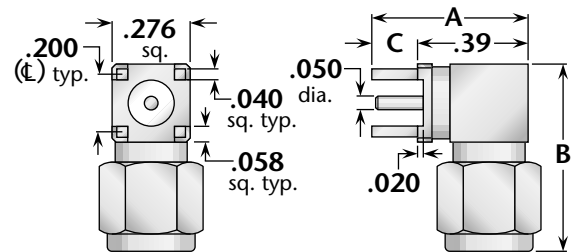

Figure 5 (Right angle plug)

Figure	Dimensions			Max. Board	Mounting Figure	Plating		Delta P/N
	A	B	C			Body	Contact	
1	.55	.394	.155	.125	PCB05	Gold*	Gold (C)	1367-000-G001-500
2	.54	.594	.155	.125	PCB05	Gold*	Gold (C)	1369-000-G001-500
3	.56	.756	.155	.125	PCB05/82	Gold*	Gold (C)	1369-000-G821-500
4	.65	.494	.155	.125	PCB05	Gold*	Gold (C)	1368-000-G001-500
5	.54	.65	.155	.125	PCB05	Gold*	Gold (C)	1370-000-G001-500

* Also available with nickel-plated body—change G in Delta part number to N.
(C) in contact plating column indicates captive contact (mechanical captivation).

Panel Plug Receptacles

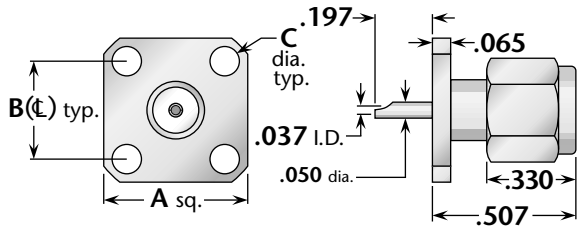

Figure 1
(Solder pot contact—square flange)

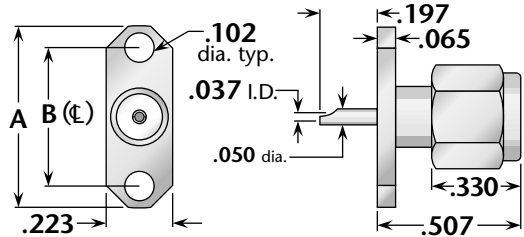

Figure 2
(Solder pot contact—2-hole flange)

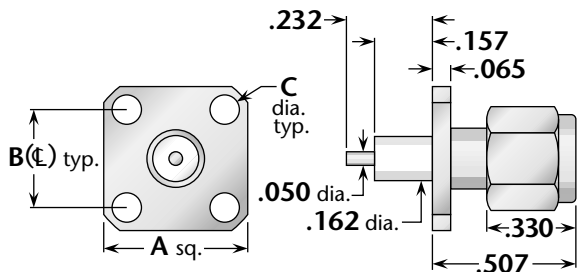

Figure 3
(Post contact—square flange)

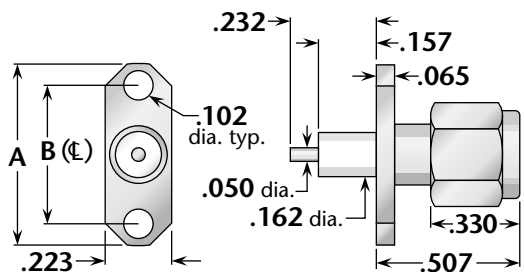

Figure 4
(Post contact—2-hole flange)

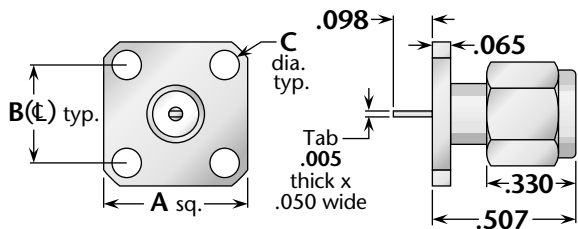

Figure 5
(Tab contact—square flange)

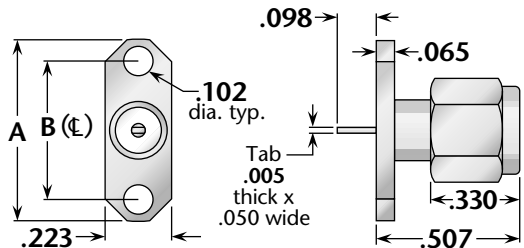

Figure 6
(Tab contact—2-hole flange)

Figure	Dimensions			Mounting Figure	Plating		Delta P/N
	A	B	C		Body	Contact	
1	.500	.340	.102	05	Gold*	Gold (C)	1323-000-G051-500
2	.625	.481	.102	92	Gold*	Gold (C)	1323-000-G921-500
3	.500	.340	.102	05	Gold*	Gold (C)	1359-000-G051-500
4	.625	.481	.102	92	Gold*	Gold (C)	1359-000-G921-500
5	.500	.340	.102	05	Gold*	Gold (C)	1359-000-G051-501
6	.625	.481	.102	92	Gold*	Gold (C)	1359-000-G921-501

* Also available with nickel-plated body—change G in Delta part number to N.
(C) in contact plating column indicates captive contact (mechanical captivation).
All items available with other flange, contact, and insulator configurations.

Straight Adapters

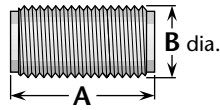

Figure 1
(Straight jack-jack; connects two plugs)

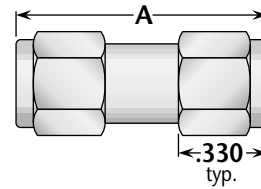

Figure 2
(Straight plug-plug; connects two jacks)

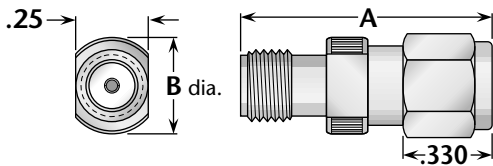

Figure 3
(Straight jack-plug; connects one plug and one jack)

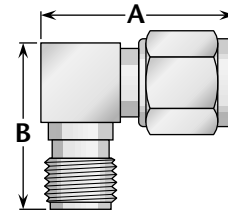

Figure 4
(Right angle plug-jack; connects one plug and one jack)

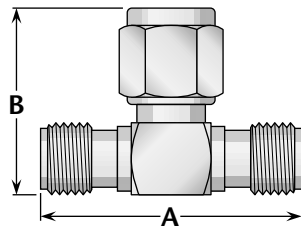

Figure 5
(Tee jack-plug-jack; connects two plugs and one jack)

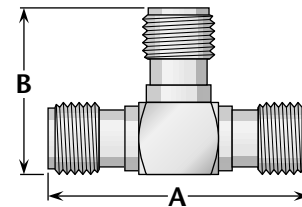
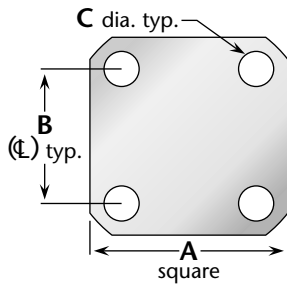

Figure 6
(Tee jack-jack-jack; connects three plugs)

Figure	Dimensions		Plating		Delta P/N
	A	B	Body	Contact	
1	.500	.250	Gold*	Gold (C)	1328-000-G001-500
2	.875	—	Gold*	Gold (C)	1327-000-G001-500
3	.86	.335	Gold*	Gold (C)	1334-000-G001-500
4	.654	.594	Gold*	Gold (C)	1329-000-G001-500
5	.913	.654	Gold*	Gold (C)	1330-000-G001-500
6	.913	.594	Gold*	Gold (C)	1338-000-G001-500

* Also available with nickel-plated body—change G in Delta part number to N.
(C) in contact plating column indicates captive contact (mechanical captivation).

Connector Flanges (Panel mounted connectors)



4-hole flanges

Figure	A	B	C
04	1/2	.360	.089
05	1/2	.340	.102
07	11/16	.500	#3-56 tap
08	11/16	.500	.136
09	11/16	.500	.125
10	11/16	.500	.120
12	11/16	.500	.109
18	3/4	.531	.136
26	1	.718	#6-32 tap
27	1	.718	#4-40 tap
30	1	.718	.166
32	1	.718	.136
32A	1	.718	.136*
33	1	.718	.125
34	13/32	.812	.150
36	13/16	.906	#6-32 tap
39	13/16	.906	.152
40	13/16	.906	.125
45	2	1.437	.257
91	.375	.250	.067
91A	.375	.232	.093

* Countersunk to .245 dia.

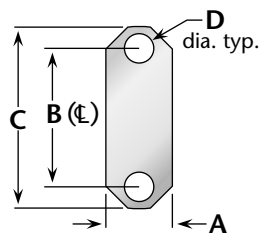

2-hole flanges

Figure	A	B	C	D
92	.223	.481	.625	.102
92A	.260	.481	.625	.102
95	.640	1.015	1.30	.125

Panel Cutouts (Bulkhead mounted connectors)

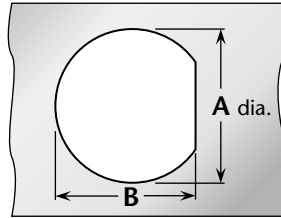

D-Hole

Figure	A	B
51	.755	.723
54	.630	.598
55	.630	.583
57	.557	.531
59	.505	.473
62	.442	.410
63	.407	.362
65	.380	.348
66	.319	.292
67	.255	.236
68	.195	.176

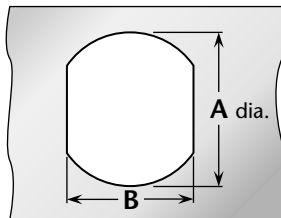

Double D-Hole

Figure	A	B
69	.755	.692
72	.630	.536
75	.380	.341
84	.319	.278

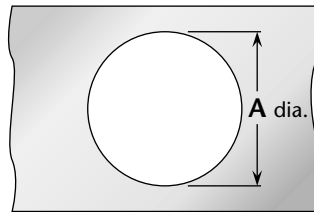

Round Hole

Figure	A
82	.255
89	.380

P.C. Board Drilling

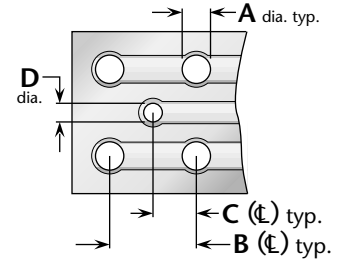

(PCB traces are shown for illustrative purpose only, and are not representative of actual circuitry.)

Coaxial connectors

Figure	A	B	C	D
PCB01	.067	.400	.200	.045
PCB02	.045	.500	.250	.045
PCB03	.067	.300	.150	.035
PCB05	.067	.200	.100	.055
PCB06	.067	.200	.100	.045

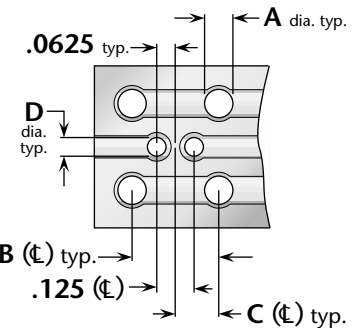

(PCB traces are shown for illustrative purpose only, and are not representative of actual circuitry.)

Twinox connectors

Figure	A	B	C	D
PCB04	.045	.500	.250	.045

Cable Group Finder			
Cable	Group	Cable	Group
RG-5, 5A, B	1A	RG-225	3C
RG-6, 6A	1B	RG-228A	20
RG-8, 8A	2A	RG-302	22
RG-9, 9A, B	3A	RG-303	23
RG-10	15	RG-304	24
RG-11, 11A	2B	RG-316	9A
RG-12	15	RG-316DS	10
RG-13A	3B	RG-393	4
RG-14A	16	RG-400	6A
RG-17A	17	RG-401	12
RG-18A	18	RG-402	13
RG-21, 21A	1A	RG-405	14
RG-22, 22A, B	28	M17/2	1B
RG-55, 55B	6B	M17/6	2B
RG-55A	6A	M17/15	28
RG-58, 58A, C	5	M17/28	5
RG-59, 59A, B	7A	M17/29	7A
RG-62, 62A, B, C	7A	M17/30	7A
RG-71, 71A, B	7B	M17/45	27
RG-108, 108A	27	M17/73	1A
RG-115A	19	M17/162	1A
RG-118A	20	M17/112	1C
RG-122	8A	M17/74	2A
RG-126	21	M17/75	3A
RG-141, 141A	5	M17/127	3C
RG-142, 142A	6A	M17/77	3B
RG-142B	6B	M17/60	6A
RG-143, 143A	1C	M18/84	6A
RG-174	9A	M17/128	6A
RG-174DS	10	M17/97	7A
RG-178, 178A, B	11	M17/54	8A
RG-179A, 179B	9B	M17/95	8B
RG-180, 180A, B	8B	M17/137	8B
RG-187, 187A	9B	M17/152	9A
RG-188, 188A	9A	M17/93	11
RG-195	8B	M17/129	12
RG-196, 196A	11	M17/130	13
RG-210	7A	M17/133	14
RG-212	1C	M17/78	16
RG-213	2A	M17/165	16
RG-214	3A	M17/176	30
RG-215	15	AT&T 735A	31
RG-217	16	Belden 8281	26
RG-218	17	Belden 9207	29
RG-219	18	Dearborn 6207	29
RG-222	1C	IBM 7362211	29
RG-223	6A		

Delta Cable Groups	
Group	Cables
1	1A RG-5, 5A, 5B, 21, 21A; M17/73, /162
	1B RG-6, 6A; M17/2
	1C RG-143, 143A, 212, 222; M17/73, /112, /162
2	2A RG-8, 8A, 213; M17/74
	2B RG-11, 11A; M17/6
3	3A RG-9, 9A, 9B, 214; M17/75
	3B RG-13A, 216; M17/77
	3C RG-225; M17/127
4	RG-393; M17/127
5	RG-58, 58A, 58C, 141, 141A; M17/28, /111
6	6A RG-55A, 142, 142A, 223, 400; M17/60, /84, /128
	6B RG-55, 55B, 142B; M17/60, /84
7	7A RG-59, 59A, 59B, 62, 62A, 62B, 62C, 210; M17/29, /30, /97
	7B RG-71, 71A, 71B; M17/90
8	8A RG-122; M17/54
	8B RG-180, 180A, 180B, 195; M17/95, /137
9	9A RG-174, 188, 188A, 316; M17/152
	9B RG-179A, 179B, 187, 187A; M17/94, /136
10	Double-Shielded RG-174, 316; M17/152
11	RG-178, 178A, 178B, 196, 196A; M17/93
12	.250" semi-rigid; RG-401; M17/129
13	.141" semi-rigid; RG-402; M17/130
14	.085" semi-rigid; RG-405; M17/133
15	RG-10, 12, 215; M17/6, /74
16	RG-14A, 217; M17/78, /165
17	RG-17A, 218
18	RG-18A, 219
19	RG-115A
20	RG-118A, 228A
21	RG-126
22	RG-302
23	RG-303
24	RG-304
25	Special 8X cable; contact factory for details.
26	Belden 8281
27	RG-108, 108A; M17/45
28	RG-22, 22A, 22B; M17/15
29	Belden 9207; Dearborn 6207; IBM 7362211
30	M17/176
31	AT&T 735A

Assembly Procedure G

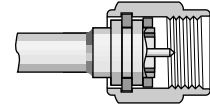
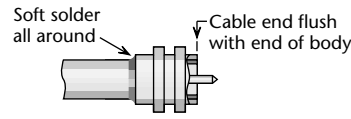
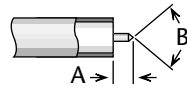
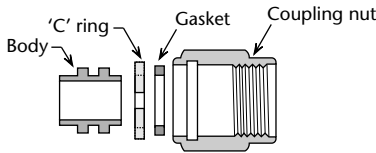

Trim Codes		
Code	A	B
G/01	.090	70-90°

1) Trim cable as shown.
Remove any burrs from jacket and center conductor.

2) Soft solder cable jacket to body, making sure that end of cable is flush with end of body. After solder joint has cooled, retrim any protruding dielectric flush with end of body.

3) Assemble 'C' ring and gasket to body. Compress 'C' ring and slide body assembly into coupling nut until ring is seated in groove.

Assembly Procedure H

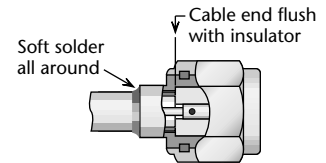
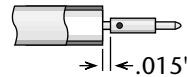
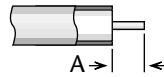
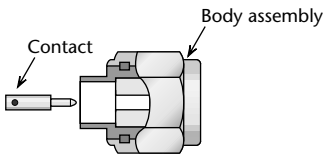

Trim Codes	
Code	A
H/01	.090
H/02	.060
H/03	.115
H/04	.150

1) Trim cable as shown.
Remove any burrs from jacket and center conductor.

2) Solder contact to center conductor, fixturing to maintain gap as shown. Remove any excess solder from outside of contact.

3) Insert cable into body and solder cable jacket to body, keeping end of cable flush with insulator as shown.

Plug body assembly and contact shown; procedure is identical for jack connectors.

Assembly Procedure I

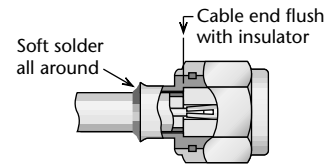
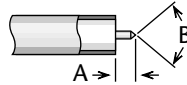
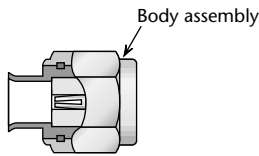

Trim Codes		
Code	A	B
I/01	.090	70-90°

1) Trim cable as shown.
Remove any burrs from jacket and center conductor.

2) Insert cable into body and solder cable jacket to body, keeping end of cable flush with insulator as shown.

Plug body assembly and contact shown; procedure is identical for jack connectors.

Cable Positioner

For .085" Cable: P/N 63-10072-2
For .141" Cable: P/N 63-10072-1

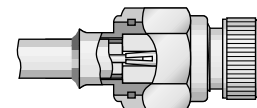
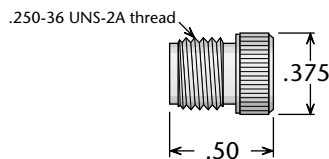

Using this positioner in the final step of assembly procedure H or I (for plugs only) will ensure that the contact and insulator are retained in the proper position to meet MIL-C-39012 requirements. The positioner should be screwed finger-tight into the mating end of the connector (as shown at right) before the cable jacket is soldered to the body assembly.

Assembly Procedure J

Trim Codes		
Code	A	B
J/01	.109	.047
J/02	.059	.039
J/03	.059	.079
J/04	.050	.059

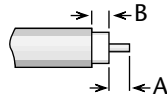

1) Trim cable as shown. Remove any burrs from jacket and center conductor.

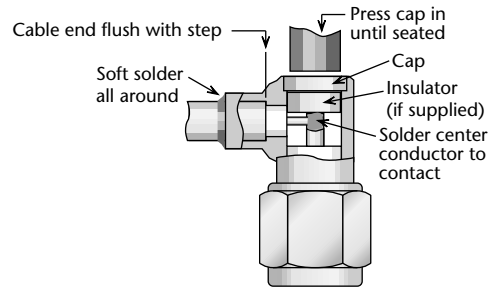

2) Soft solder cable jacket to body, making sure that end of cable is flush with step in body. Solder center conductor into contact slot, assemble insulator disc (if supplied), then press cap into body until seated or screw into place.

Assembly Procedure K

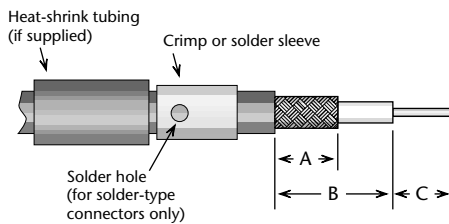

1) Trim cable per chart. Slide crimp (or solder) sleeve and heat-shrink tubing (if supplied) back onto cable.

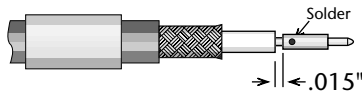

2) Solder contact onto center conductor, fixturing to maintain gap as shown. Flare cut end of braid slightly by rotating dielectric.

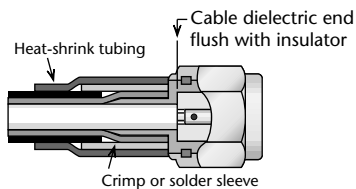

3) Insert cable/contact into rear of body, with all braid wires on outside of crimp tail. Push cable in until cable dielectric bottoms in connector. Trim excess braid wires even with shoulder of body. Slide crimp sleeve forward until flush with body and crimp (see page 190 for hex die sizes). (For solder-type connectors, solder braid to body and sleeve through hole in sleeve.) Slide heat-shrink tubing into place and shrink with hot-air gun.

Plug body assembly and contact shown; procedure is identical for jack connectors.

Trim Codes							
Code	A	B	C	Code	A	B	C
K/01	.250	.270	.110	K/06	.250	.315	.095
K/02	.200	.270	.140	K/07	.220	.290	.135
K/03	.225	.290	.110	K/08	.420	.620	.090
K/04	.225	.330	.110	K/09	.090	.135	.160
K/05	.250	.330	.110	K/10	.250	.415	.115
				K/11	.250	.400	.150

Assembly Procedure L

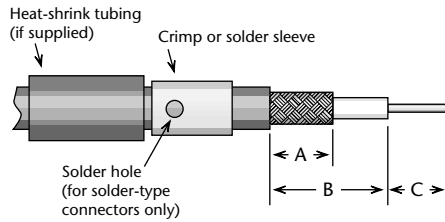

1) Trim cable per chart. Slide crimp (or solder) sleeve and heat-shrink tubing (if supplied) back onto cable.

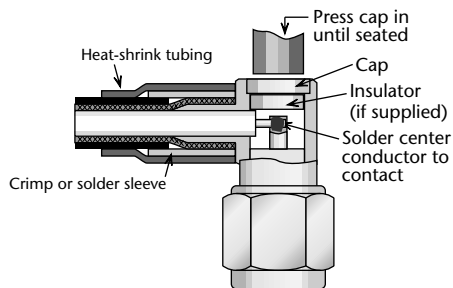

2) Insert cable into rear of body, with all braid wires on outside of crimp tail. Push cable in until end of braid touches connector body shoulder and center conductor rests in contact slot. Trim excess braid wires even with shoulder of body.

Slide crimp sleeve forward until flush with body and crimp (see page 176 for hex die sizes). (For solder-type connectors, solder braid to body and sleeve through hole in sleeve.)

Slide heat-shrink tubing into place and shrink with hot-air gun. Solder center conductor into contact slot, assemble insulator disc (if supplied), then press cap into body until seated or screw into place.

Trim Codes			
Code	A	B	C
L/01	.250	.438	.109
L/02	.125	.219	.109
L/03	.234	.344	.109
L/04	.195	.270	.050
L/05	.095	.155	.050

Crimp Tools for Flexible Cable

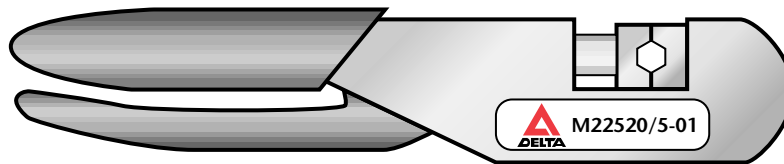

Frame only—P/N M22520/5-01—Use with interchangeable dies listed below.

For Cable Group(s)	Hex Die Size	Die Set P/N	Closure
2, 3, 4	.429 hex, .400 wide	M22520/5-61	A
5, 6	.213 hex, .400 wide	M22520/5-19	B
7	.255 hex, .400 wide	M22520/5-19	A
9	.128 hex, .400 wide	M22520/5-35	B
10	.151 hex, .400 wide	M22520/5-37	B
11	.105 hex, .400 wide	M22520/5-33	B



Warranty

We warrant our parts to be free from defects in materials and workmanship for one year from date of purchase. During that time, we will repair or replace (at our option) any parts found to be defective.

This warranty does not apply to parts which have been modified, used in conditions exceeding Delta or military specifications, or disassembled. We will not, under any circumstances, be responsible for consequential or incidental damages or installation costs.

No other warranties apply, and no other liability may be assumed or extended by representatives or distributors.

Returns

Returns will be accepted only with a Return Authorization number issued by Delta, and are subject to inspection and acceptance upon arrival. Restocking charges will be determined prior to issuance of Return Authorization.

All claims for shortages must be made within 30 days of receipt by customer.

Ordering Information

Orders are subject to the terms and conditions on our order acknowledgement, which may only be modified by written agreement prior to sale. Order changes, cancellation, or termination will be accepted only with written approval from Delta Electronics Manufacturing.

Copyright, Trademarks, and Patents

Entire contents copyright 2003, Delta Electronics Manufacturing Corporation. Reproduction rights are hereby granted for, and specifically limited to, printing or other reproduction of drawings and specifications for inclusion in specification or source control drawings, or for purchasing procedures, by Delta customers only.

Heli-Grip, *PressMount*, and the New England Craftsmanship logo are trademarks. The Heli-Grip design is covered by U.S. and foreign patents.

Delta Electronics Manufacturing Corporation
416 Cabot Street, P.O. Box 53
Beverly, MA 01915
FSCM/CAGE 00795

Catalog # Elinepdf 1.2 (7/09)