



TNC Connectors

ONLINE CATALOG

Contents

CLICK ON ANY LINE TO GO DIRECTLY TO THE INDICATED PAGE

Navigation Guide	2
Specifications and interface dimensions.	3
Design Features	4

Cable Connectors

Straight Cable Plugs	8
Right Angle Cable Plugs.	10
Straight Cable Jacks	12
Bulkhead Cable Jacks	13
Panel Cable Jacks	14

Receptacles

Panel Jack Receptacles	15
Right Angle Panel Jack Receptacles	16
Panel Plug Receptacles.	16
Bulkhead Jack Receptacles	17
PressMount Receptacles.	18
Stripline Receptacles	18

Accessories

Resistive Terminations	19
Dust Caps.	19
Keying baskets.	20
In-Series Adapters	21

Polarized TNC Connectors

Cable Plugs and Jacks.	23
Receptacles	23

Technical Information

Mounting Figures	24
Cable Groups.	25
Cable Assembly Instructions	26
Assembly Tooling.	28
Ordering and Warranty	29

We have configured this online catalog to take advantage of Acrobat navigation shortcuts (links). However, these links are not visible on the pages— making them visible would compromise the page’s readability.

- Clicking on any entry in the Table of Contents will take you to the indicated page.
- Shown below are the “hot spots” on all of the product pages that will take you to background information on various connector characteristics.
- After you use a link to jump to another page, you can use the “back” arrow in Acrobat’s menu bar to return to the page you jumped from.
- Configure Acrobat Reader to show bookmarks for a table of contents by specific characteristic (for example, cable plugs broken out by cable attachment method).
- To find a specific part number, use Acrobat’s search feature.

In addition, the pages are formatted to fit within the margins of standard laser or inkjet printers—no need to use the “shrink to fit” option when printing pages from Acrobat.

Click [here](#) to go to the Table of Contents

Click on the Delta logo on any page to jump to the table of contents.

Click on the page title to jump to specifications and interface dimensions.

BNC Cable Jacks

Panel Jack—Military Clamp for Flexible Cable

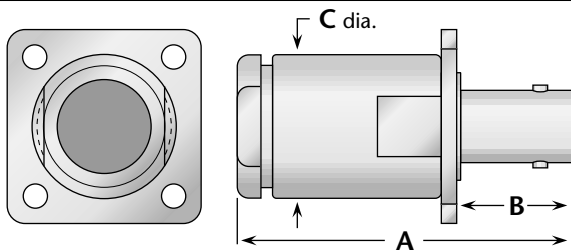

Figure 1

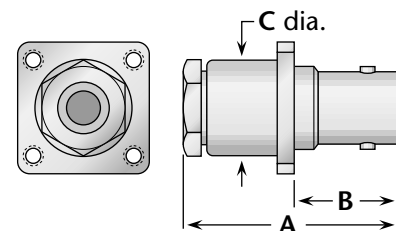

Figure 2

Cable Group	Fig.	Dimensions			Mounting Figure	Plating		Delta P/N	Assembly Procedure/Trim Code
		A	B	C		Body	Contact		
1	1	1.75	.63	.75	33	Nickel	Silver	1011-001-N330	A/20
2, 3	1	1.75	.63	.75	33	Nickel	Silver	1011-004-N330	A/20
5, 6	2	1.16	.55	.50	07	Nickel	Silver	UG-291C/U	A/17

Click here to jump to dimensions for Delta mounting figures.

Click here to jump to the cable assembly procedure for this connector.

Click here to jump to information on alternate body plating.

Click here to jump to a guide to Delta cable groups.

Click here to go to Delta’s website if your computer is configured for Web connection via Acrobat.

General Description

Delta TNC connectors are compact, 50Ω impedance connectors with 7/16-28 threaded coupling, similar in size to BNC connectors but with better electrical characteristics. They are best suited for use with cables in the range of .150" to .250" diameter, but are available for other cables from .090" to over .75" diameter. Our extensive line of TNC receptacles includes configurations for virtually any packaging requirement, and we can supply any adapter or accessory you need to complete your system design.

As with our other connector series, Delta's *customer-driven design* results in TNC series connectors with practical and unique features that make your design and assembly process easier. Some of these include:

- *Heli-Grip* cable connectors for fast, reliable assembly to flexible cable without special tooling.
- *PressMount* receptacles (page 18) mount securely in a single round hole, saving space on your components and reducing your housing fabrication costs.
- Panel receptacles with flange sizes to match the same hole pattern as standard SMA or type N connectors, letting you drill one hole pattern and mount BNC, N, SMA, TNC, or 7/16 series connectors as needed.
- TNC connectors with polarized interfaces prevent mismatching and meet FCC Part 15.203 requirements.
- Keying baskets and keyed plugs (page 20) provide numerous polarizations in applications that incorporate multiple connector pairs.

For adapters between TNC and other series, download the document *DeltaABS.pdf* from our website.

TNC Specifications*

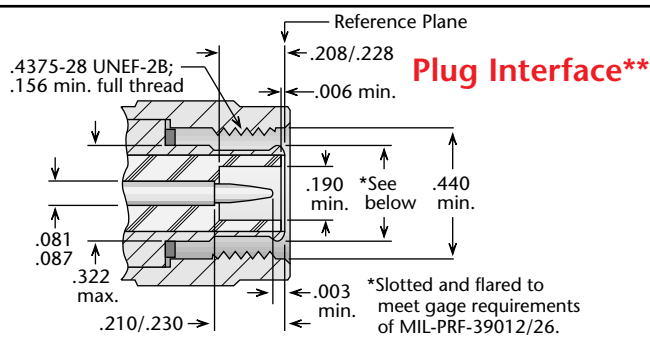

Electrical:

Nominal Impedance: 50 ohms.
Frequency Range: DC–11 GHz.
Voltage Rating: 500 volts RMS.
Dielectric Withstanding Voltage: 1,500 VRMS.
Insulation Resistance: 5,000 megohms.

Materials/Finishes:

Insulators: Teflon per ASTM D1710.
Male Contacts: Brass per ASTM B16.
Female Contacts: Beryllium Copper per ASTM B196.
Contact Plating: Silver per QQ-S-365, or Gold per MIL-G-45204.

Gaskets: Silicone rubber per ZZ-R-765, Class II, Grade 50.

Other Metal Parts: Brass per ASTM B16, plated: Silver per QQ-S-365, or Nickel per QQ-N-290.

All other specifications are in accordance with the latest issues of MIL-PRF-39012, or MIL-A-55339, or other applicable MIL specifications, and interfaces are in accordance with MIL-STD-348.

*These specifications are typical and may not apply to all connectors. Detailed specifications for individual connectors are available on request.

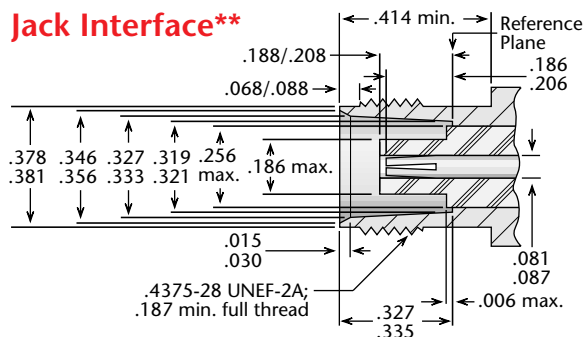

**Some proportions altered to illustrate detail.

About Delta's Customer-Driven Design

At Delta, *Customer-Driven Design* isn't just a catchy slogan. It means that we make RF connectors that help you build your products efficiently, quickly, and cost-effectively. Because we design for *your* needs, nobody else can offer you such a broad line of standard connectors, along with an ever-growing list of innovative, user-friendly design variations like those detailed on these pages.

These featured connector technologies grew out of real-world requirements, and have saved our customers untold hours and dollars over the years. And there are thousands of other special connector designs we've produced that we don't have space to include in this catalog. So if you don't see the exact connector configuration you need, please call us—we may have already made it. If not, we'll work with you to provide the the connectors you need, with the best price/performance balance in the business, and with quality and delivery that will enhance your products and production schedules.

Design Features

Plating options.....	4
Panel receptacles with common flange sizes	5
PressMount receptacles	6
Plugs and jacks with polarized mating	6
Heli-Grip connectors for flexible cable	7
Coupling nut options.....	7

Plating Options for Economy and Performance

(Albaloy or nickel—available for all connector series except SMA)

Silver plating has long been standard on RF connectors with brass bodies, but its high cost and low corrosion resistance make it less than ideal in most applications. Nickel plating is less expensive and more durable than silver, and is standard on many of our connectors.

However, in some applications, nickel plating can introduce unwanted intermodulation distortion, particularly on large size connectors. For these applications, we offer optional Albaloy plating, a tin/zinc/copper composite with a bright white finish, the corrosion resistance of nickel, and the low intermodulation distortion of silver plating.

Albaloy plating has the same composition as, and is fully compatible with, other commercial platings designated Sucoplate[®], IP-23, White Bronze, and Tri-Alloy.

To order a Delta connector with plating other than the listed finish, substitute **A**, **N**, or **Q** in the Delta part number as below:

For **silver** plating: 1111-111-**A**111.

For **nickel** plating: 1111-111-**N**111.

For **Albaloy** plating: 1111-111-**Q**111.

Note: M39012 and M55339 QPL connectors can only be supplied with the specified plating. SMA connectors with stainless-steel bodies are available with gold plating or passivated finish.

Common Flange Sizes Simplify Your Production

(Available on BNC, N, SMA, TNC, and 7/16 series connectors as noted in product pages)

Does it make sense that you have to drill your components with different mounting hole patterns whenever you need to ship them with a different connector series attached? We didn't think so, either.

That's why we offer a wide range of connectors in different series with common flange sizes and contact/insulator configurations. Now you can streamline your production process and shorten your delivery cycle—just predrill your components with one mounting hole pattern, and ship them with the connectors your customers require.

Flange Sizes and Available Interfaces

1/2" square flange (Delta mounting figure 05)—standard flange size for SMA

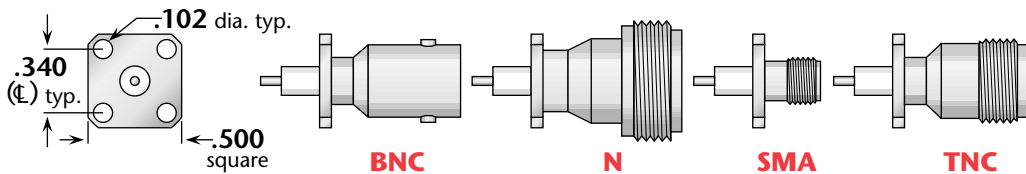

11/16" square flange (Delta mounting figure 09)—standard flange size for BNC, TNC

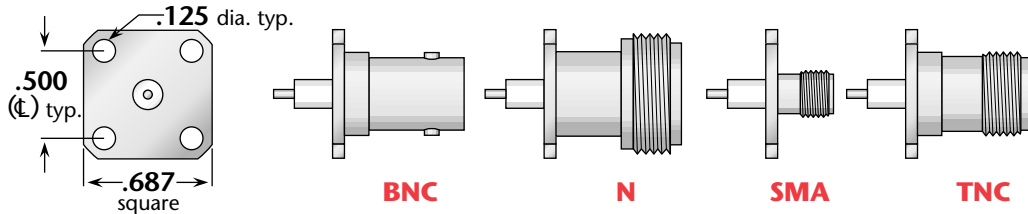

1" square flange (Delta mounting figure 33)—standard flange size for type N

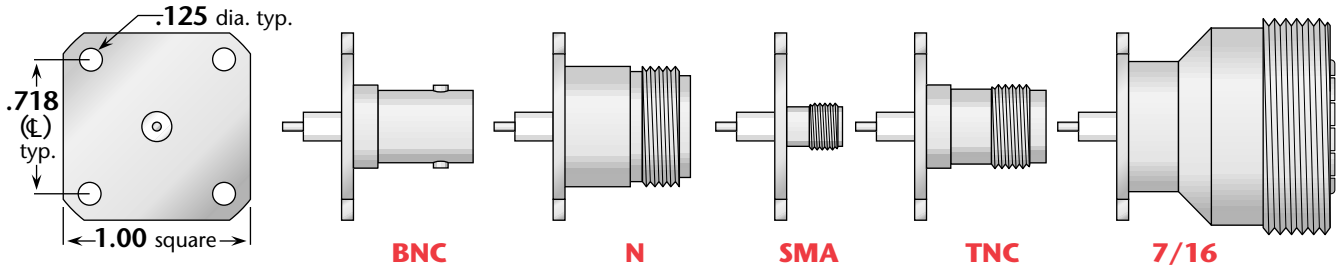

Contact and insulator configurations are shown for illustration only—these connectors are available with a wide variety of post, tab, solder pot, or slotted contacts. Standard configurations are shown on product pages, and your request for a custom design is always welcome.

Delta PressMount Receptacles

Connector design

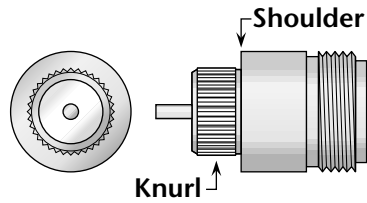

As mounted on component

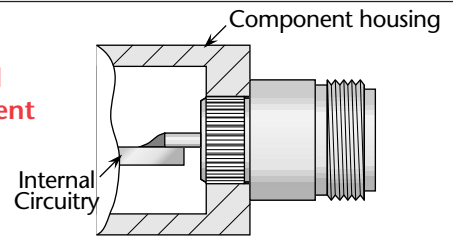

Delta PressMount receptacles eliminate the need for complicated mounting hole patterns and mounting hardware. They are simply pressed into a single through hole, and can be used in component housings as small as the outer diameter of the connector. An integral shoulder provides a positive depth stop during mounting.

Besides the standard types shown below and in the product pages, PressMount receptacles are available with a wide variety of contact and insulator configurations—please call if you don't see what you need.

Standard TNC PressMount Receptacles

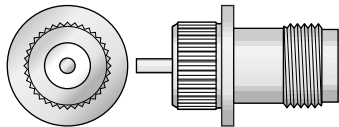

TNC jack
(Solder pot or post contact—page 18)

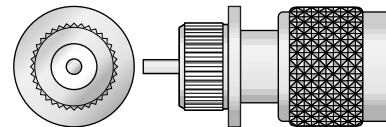

TNC plug
(Post contact—page 18)

Polarized TNC Connectors Prevent Mismatching

(See page 23 for standard types)

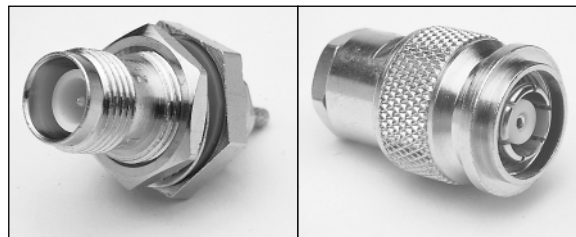

FCC Part 15.203 requirements mandate the use of a nonstandard interface in spread-spectrum wireless applications, and further specify that the connectors must not be damaged when an attempt is made to mate them with standard connectors. Delta's polarized TNC plugs and jacks meet these requirements without the additional expense of other designs, such as connectors with left-hand threads.

For systems that need more than two polarizations to prevent mismatching of connector pairs, see our unique line of keying baskets and keyed plugs on page 20.

SMA connector pairs can also be provided with reverse polarity—call for availability.

Heli-Grip® Cable Attachment—for Flexible Cable

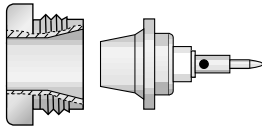

**Backnut; cone/contact/
insulator subassembly**

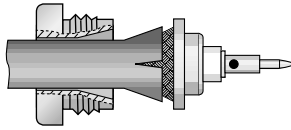

**Cable assembled to
hardware subassembly**

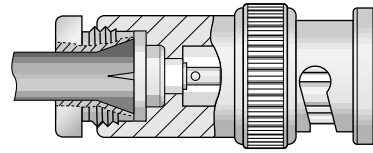

(Proportions altered to illustrate detail)
As assembled in connector

With their reduced parts count and rapid assembly, Delta's Heli-Grip connectors offer you significant time savings in your cable assembly operation, without the need for dedicated crimp tools.

Heli-Grip connectors all have captivated contacts, and assembly is easy—simply trim the cable, slide the trimmed cable into the cone/insulator/contact assembly (left), solder the center conductor to the contact, and screw the body assembly (right) onto the backend assembly.

Heli-Grip connectors have cable retention strength greater than the force required to tear the cable braid.

Standard TNC Heli-Grip Configurations

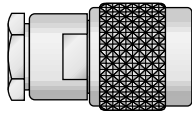

Straight plug—page 9

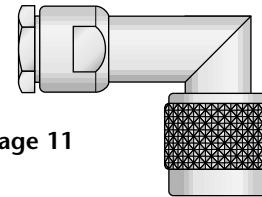

Right angle plug—page 11

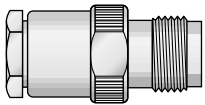

Straight jack—page 12

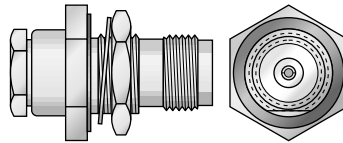

Bulkhead jack—page 13

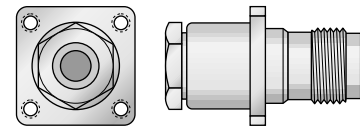

Panel jack—page 14

Coupling Nut Options

TNC plugs can be supplied with a hex coupling nut for applications requiring plugs to be torqued to a specific value. Please call for part numbers of specific connectors with hex coupling nuts, which can be supplied with or without safety-wire holes.

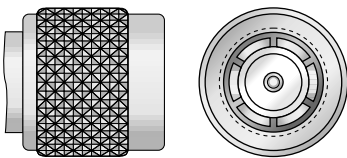

Standard coupling nut

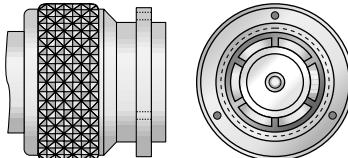

**Standard coupling nut
with lockwire holes**

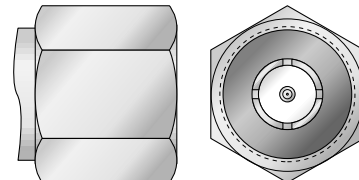

Hex coupling nut

Straight Plug—Military Clamp for Flexible Cable

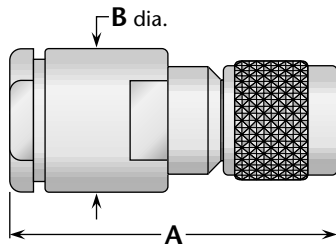

Figure 1
(Standard coupling nut)

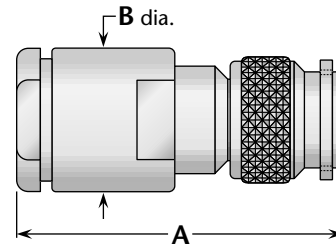

Figure 2
(Safety-wire holes in coupling nut)

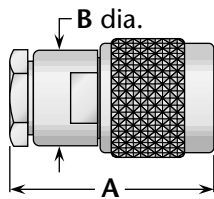

Figure 3
(Standard coupling nut)

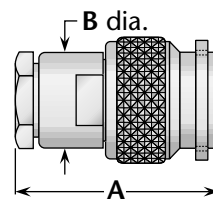

Figure 4
(Safety-wire holes in coupling nut)

Cable Group	Figure	Dimensions		Plating		Delta P/N	Assembly Procedure/ Trim Code
		A	B	Body	Contact		
1	1	1.66	.75	Nickel	Gold	1201-001-N000	A/01
2, 3	1	1.66	.75	Nickel	Gold	1201-004-N000	A/01
2, 3	1	1.66	.75	Nickel	Gold (C)	1201-004-N001-4	A/01
2, 3	2	1.66	.75	Nickel	Gold	1240-004-N000	A/01
2, 3	2	1.66	.75	Nickel	Gold (C)	1240-004-N001	A/01
5, 6	3	1.09	.50	Nickel	Gold	1201-015-N000	A/17
5, 6	3	1.09	.50	Nickel	Gold (C)	1201-015-N001	A/17
5, 6	4	1.09	.50	Nickel	Gold	1240-015-N000	A/17
5, 6	4	1.09	.50	Nickel	Gold (C)	1240-015-N001	A/17
7	3	1.09	.50	Nickel	Gold	1201-021-N000	A/17
7	3	1.09	.50	Nickel	Gold (C)	1201-021-N001	A/17
7	4	1.09	.50	Nickel	Gold	1240-021-N000	A/17
7	4	1.09	.50	Nickel	Gold (C)	1240-021-N001	A/17
8A	3	1.09	.50	Nickel	Gold	1201-029-N000	A/17
8A	3	1.09	.50	Nickel	Gold (C)	1201-029-N001	A/17
8B	3	1.09	.50	Nickel	Gold	1201-043-N000	A/17
8B	3	1.09	.50	Nickel	Gold (C)	1201-043-N001	A/17
9	3	1.09	.50	Nickel	Gold	1201-036-N000	A/18
9	3	1.09	.50	Nickel	Gold (C)	1201-036-N001-2	A/18
9	4	1.09	.50	Nickel	Gold	1240-036-N000	A/18
9	4	1.09	.50	Nickel	Gold (C)	1240-036-N001	A/18
11	3	1.09	.50	Nickel	Gold	1201-038-N000	A/18
11	3	1.09	.50	Nickel	Gold (C)	1201-038-N001	A/18

(C) in contact plating column indicates captive contact.

Straight Plug—Heli-Grip® for Flexible Cable

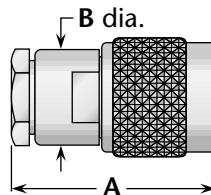
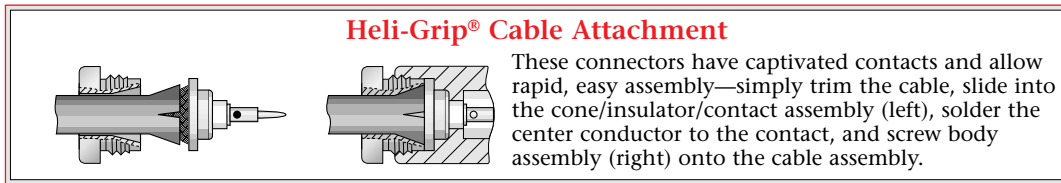

Figure 1

Cable Group	Figure	Dimensions		Plating		Delta P/N	Assembly Procedure/ Trim Code
		A	B	Body	Contact		
5, 6 [§]	1	1.09	.50	Nickel	Silver (C)	1201-018-N005	E/03
RG-223	1	1.09	.50	Nickel	Silver (C)	1201-015-N005	E/03
7	1	1.09	.50	Nickel	Silver (C)	1201-019-N005	E/03
8A	1	1.09	.50	Nickel	Silver (C)	1201-029-N005	E/03
8B	1	1.09	.50	Nickel	Silver (C)	1201-043-N005	E/03
9	1	1.09	.50	Nickel	Silver (C)	1201-037-N005	E/03
10	1	1.09	.50	Nickel	Silver (C)	1201-100-N005	E/03
11	1	1.09	.50	Nickel	Silver (C)	1201-038-N005	E/03

§Except RG-223/U.

Straight Plug—Crimp Type for Flexible Cable

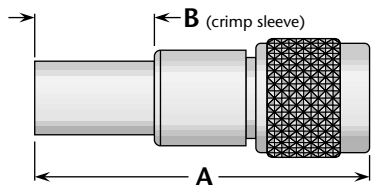

Figure 1

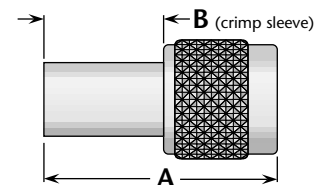

Figure 2

Cable Group	Figure	Dimensions		Plating		Delta P/N	Assembly Procedure/ Trim Code
		A	B	Body	Contact		
3A, 4	1	1.75	.63	Nickel	Gold	1203-005-N000	B/11
5	2	1.06	.50	Nickel	Gold	1203-017-N000	B/23
6	2	1.06	.50	Nickel	Gold	1203-013-N000	B/23
7	2	1.06	.50	Nickel	Gold	1203-020-N000	B/23
7	2	1.04	.50	Nickel	Silver	1203-020-N000-3*	***
7	2	1.04	.50	Nickel	Gold	1203-020-N000-5*	***
7	2	1.06	.50	Nickel	Gold (C)	1203-020-N001-3*	***

* Crimp center contact.

***Contact factory for cable assembly instructions. • (C) in contact plating column indicates captive contact.

Straight Plug—Solder-Clamp for Semi-Rigid Cable

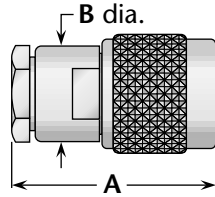

Figure 1
(Standard coupling nut)

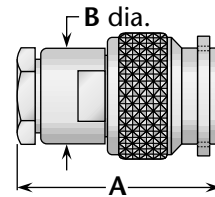

Figure 2
(Safety-wire holes in coupling nut)

Cable Group	Figure	Dimensions		Plating		Delta P/N	Assembly Procedure/ Trim Code
		A	B	Body	Contact		
13	1	1.09	.50	Nickel*	Gold	1201-031-N003	F/08
13	2	1.09	.50	Nickel*	Gold	1240-031-N003	F/08
14	1	1.09	.50	Nickel*	Gold	1201-025-N003	F/07
14	2	1.09	.50	Nickel*	Gold	1240-025-N003	F/07

* Solder ferrule is gold plated.

Right Angle Plug—Military Clamp for Flexible Cable

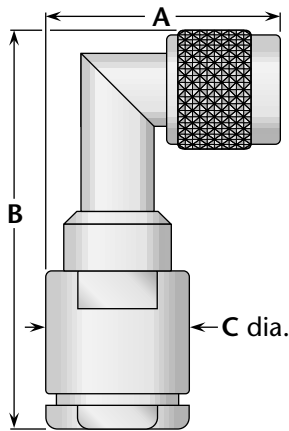

Figure 1

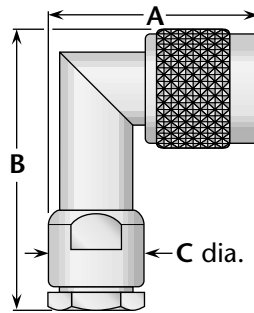

Figure 2

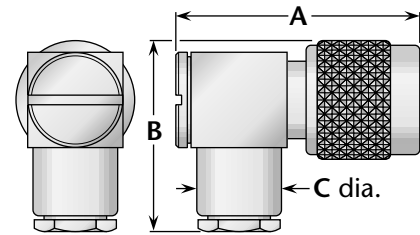
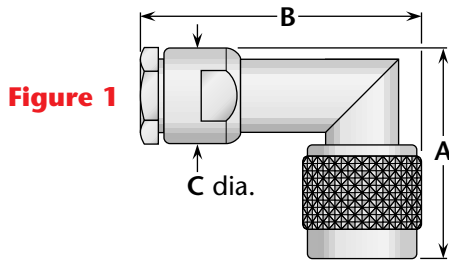

Figure 3

Cable Group	Figure	Dimensions			Plating		Delta P/N	Assembly Procedure/ Trim Code
		A	B	C	Body	Contact		
1	1	1.19	1.94	.75	Nickel	Gold	1204-001-N000	A/07
2, 3	1	1.19	1.94	.75	Nickel	Gold	1204-004-N000	A/07
2, 3	1	1.19	1.94	.75	Nickel	Gold (C)	1204-004-N001	A/07
5, 6	2	1.06	1.65	.50	Nickel	Gold	1204-015-N000	A/17
5, 6	2	1.06	1.65	.50	Nickel	Gold (C)	1204-015-N001	A/17
5, 6	3	1.20	1.11	.50	Nickel	Gold (C)	1205-018-N000	A/19
7	2	1.06	1.65	.50	Nickel	Gold	1204-021-N000	A/17
7	2	1.06	1.65	.50	Nickel	Gold (C)	1204-021-N001	A/17
7	3	1.20	1.11	.50	Nickel	Gold (C)	1205-021-N000	A/19
8A	3	1.20	1.11	.50	Nickel	Gold (C)	1205-029-N000	A/19
9	2	1.06	1.65	.50	Nickel	Gold	1204-036-N000	A/18
9	3	1.20	1.11	.50	Nickel	Gold (C)	1205-036-N000-1	A/19

(C) in contact plating column indicates captive contact.

Right Angle Plug—Heli-Grip® for Flexible Cable



Heli-Grip® Cable Attachment

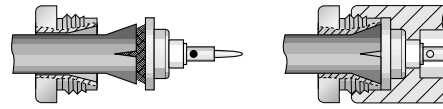

These connectors have captivated contacts and allow rapid, easy assembly—simply trim the cable, slide into the cone/insulator/contact assembly (left), solder the center conductor to the contact, and screw body assembly (right) onto cable assembly.

Cable Group	Figure	Dimensions			Plating		Delta P/N	Assembly Procedure/ Trim Code
		A	B	C	Body	Contact		
5, 6 [§]	1	1.06	1.65	.50	Nickel	Silver (C)	1204-018-N005	E/03
RG-223	1	1.06	1.65	.50	Nickel	Silver (C)	1204-015-N005	E/03
7	1	1.06	1.65	.50	Nickel	Silver (C)	1204-019-N005	E/03
8A	1	1.06	1.65	.50	Nickel	Silver (C)	1204-029-N005	E/03
8B	1	1.06	1.65	.50	Nickel	Silver (C)	1204-043-N005	E/03
9	1	1.06	1.65	.50	Nickel	Silver (C)	1204-037-N005	E/03
10	1	1.06	1.65	.50	Nickel	Silver (C)	1204-100-N005	E/03
11	1	1.06	1.65	.50	Nickel	Silver (C)	1204-038-N005	E/03

§Except RG-223/U.

Right Angle Plug—Crimp Type for Flexible Cable

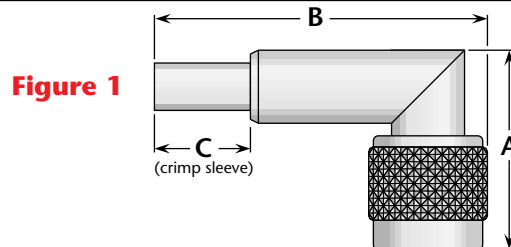

Cable Group	Figure	Dimensions			Plating		Delta P/N	Assembly Procedure/ Trim Code
		A	B	C	Body	Contact		
5	1	1.03	1.72	.50	Nickel	Gold	1207-017-N000	B/02
6	1	1.03	1.72	.50	Nickel	Gold	1207-015-N000	B/02
7	1	1.03	1.72	.50	Nickel	Gold	1207-020-N000	B/02

Right Angle Plug—Solder-Clamp for Semi-Rigid Cable

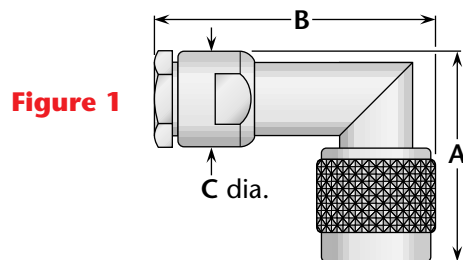

* Solder ferrule is gold plated.

Cable Group	Figure	Dimensions			Plating		Delta P/N	Assembly Procedure/ Trim Code
		A	B	C	Body	Contact		
13	1	1.06	1.65	.50	Nickel*	Gold	1204-031-N003	F/08
14	1	1.06	1.65	.50	Nickel*	Gold	1204-025-N003	F/07

(C) in contact plating column indicates captive contact.

Straight Jacks—For Flexible and Semi-Rigid Cable

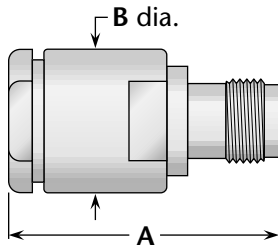

Figure 1

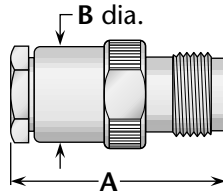

Figure 2

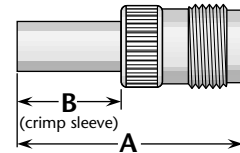

Figure 3

Heli-Grip® Cable Attachment (where noted)



These connectors have captivated contacts and allow rapid, easy assembly—simply trim the cable, slide into the cone/insulator/contact assembly (left), solder the center conductor to the contact, and screw body assembly (right) onto the cable assembly.

Military Clamp for Flexible Cable

Cable Group	Figure	Dimensions		Plating		Delta P/N	Assembly Procedure/ Trim Code
		A	B	Body	Contact		
1	1	1.75	.75	Nickel	Gold	1208-001-N000	A/20
2, 3	1	1.75	.75	Nickel	Gold	1208-004-N000	A/20
5, 6	2	1.16	.50	Nickel	Gold	1208-015-N000	A/17
5, 6	2	1.16	.50	Nickel	Gold (C)	1208-015-N001	A/17
7	2	1.16	.50	Nickel	Gold	1208-021-N000	A/17
7	2	1.16	.50	Nickel	Gold (C)	1208-021-N001	A/17
9	2	1.16	.50	Nickel	Gold	1208-036-N000	A/18
9	2	1.16	.50	Nickel	Gold (C)	1208-036-N001	A/18
11	2	1.16	.50	Nickel	Gold	1208-038-N000	A/18

Heli-Grip for Flexible Cable

5, 6 [§]	2	1.16	.50	Nickel	Silver (C)	1208-018-N005-1	E/03
RG-223	2	1.16	.50	Nickel	Silver (C)	1208-015-N005	E/03
7	2	1.16	.50	Nickel	Silver (C)	1208-019-N005	E/03
8A	2	1.16	.50	Nickel	Silver (C)	1208-029-N005	E/03
8B	2	1.16	.50	Nickel	Silver (C)	1208-043-N005	E/03
9	2	1.16	.50	Nickel	Silver (C)	1208-037-N005	E/03
10	2	1.16	.50	Nickel	Silver (C)	1208-100-N005	E/03
11	2	1.16	.50	Nickel	Silver (C)	1208-038-N005	E/03

Crimp Type for Flexible Cable

5	3	1.16	.50	Nickel	Gold	1210-017-N000	B/05
6	3	1.16	.50	Nickel	Gold	1210-013-N000	B/05
7	3	1.16	.50	Nickel	Gold	1210-020-N000	B/05
7	3	1.06	.41	Nickel	Silver	1210-020-N001**	***

Solder-Clamp for Semi-Rigid Cable

13	2	1.16	.50	Nickel*	Gold	1208-031-N003	F/08
14	2	1.16	.50	Nickel*	Gold	1208-025-N003	F/07

[§]Except RG-223/U.

*Solder ferrule is gold plated.

(C) in contact plating column indicates captive contact.

Indicates crimp center contact. • *Contact factory for cable assembly instructions.

Bulkhead Jacks—For Flexible and Semi-Rigid Cable

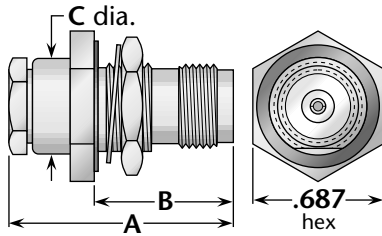

Figure 1
(Rear mount)

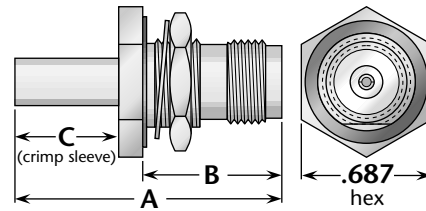
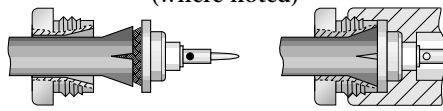

Figure 2
(Rear mount)

Heli-Grip® Cable Attachment (where noted)



These connectors have captivated contacts and allow rapid, easy assembly—simply trim the cable, slide into the cone/insulator/contact assembly (left), solder the center conductor to the contact, and screw body assembly (right) onto the cable assembly.

Military Clamp for Flexible Cable

Cable Group	Fig.	Dimensions			Mounting Figure	Max. Panel	Plating		Delta P/N	Assembly Procedure/Trim Code
		A	B	C			Body	Contact		
5, 6	1	1.16	.68	.50	59	.11	Nickel	Gold	1216-015-N590	A/17
5, 6	1	1.16	.68	.50	59	.11	Nickel	Gold (C)	1216-015-N591	A/17
5, 6	1	1.16	.81	.50	59	.24	Nickel	Gold (C)	1216-015-N59E	A/17
7	1	1.16	.68	.50	59	.11	Nickel	Gold	1216-021-N590-2	A/17
7	1	1.16	.68	.50	59	.11	Nickel	Gold (C)	1216-021-N591	A/17
7	1	1.16	.81	.50	59	.24	Nickel	Gold (C)	1216-021-N59E	A/17
9	1	1.16	.68	.50	59	.11	Nickel	Gold	1216-036-N590	A/17
9	1	1.16	.68	.50	59	.11	Nickel	Gold (C)	1216-036-N591-5	A/18
11	1	1.16	.68	.50	59	.11	Nickel	Gold	1216-038-N590-2	A/18
11	1	1.16	.68	.50	59	.11	Nickel	Gold (C)	1216-038-N591-1	A/18

Heli-Grip for Flexible Cable

5, 6 [§]	1	1.16	.81	.50	59	.24	Nickel	Silver (C)	1216-018-N595	E/03
RG-223	1	1.16	.81	.50	59	.24	Nickel	Silver (C)	1216-015-N595-1	E/03
7	1	1.16	.81	.50	59	.24	Nickel	Silver (C)	1216-019-N595	E/03
8A	1	1.16	.81	.50	59	.24	Nickel	Silver (C)	1216-029-N595	E/03
8B	1	1.16	.81	.50	59	.24	Nickel	Silver (C)	1216-043-N595	E/03
9	1	1.16	.81	.50	59	.24	Nickel	Silver (C)	1216-037-N595	E/03
10	1	1.16	.81	.50	59	.24	Nickel	Silver (C)	1216-100-N595-2	E/03
11	1	1.16	.81	.50	59	.24	Nickel	Silver (C)	1216-038-N595	E/03

Crimp Type for Flexible Cable

5	2	1.31	.68	.50	59	.11	Nickel	Gold	1219-017-N590	B/13
6	2	1.31	.68	.50	59	.11	Nickel	Gold	1219-013-N590-2	B/13
7	2	1.31	.68	.50	59	.11	Nickel	Gold	1219-020-N590	B/13

Solder-Clamp for Semi-Rigid Cable

13	1	1.16	.68	.50	59	.11	Nickel*	Gold	1216-031-N593	F/08
14	1	1.16	.68	.50	59	.11	Nickel*	Gold	1216-025-N593	F/07

[§]Except RG-223/U.

* Solder ferrule is gold plated.

(C) in contact plating column indicates captive contact.

Bulkhead Jacks—For Flexible and Semi-Rigid Cable

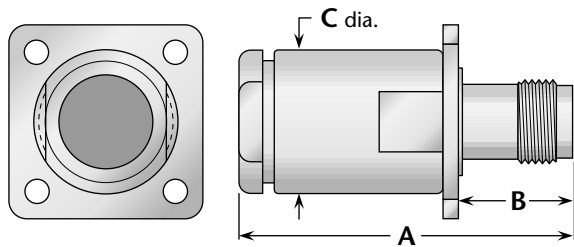

Figure 1

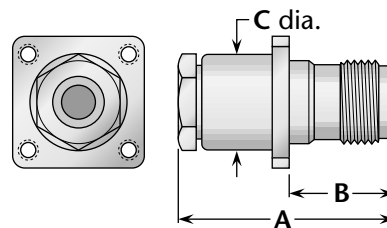
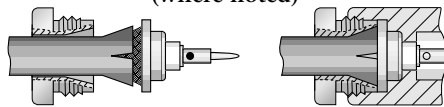

Figure 2

Heli-Grip® Cable Attachment (where noted)



These connectors have captivated contacts and allow rapid, easy assembly—simply trim the cable, slide into the cone/insulator/contact assembly (left), solder the center conductor to the contact, and screw body assembly (right) onto the cable assembly.

Military Clamp for Flexible Cable

Cable Group	Fig.	Dimensions			Mounting Figure	Plating		Delta P/N	Assembly Procedure/Trim Code
		A	B	C		Body	Contact		
1	1	1.75	.63	.75	33	Nickel	Gold	1211-001-N330	A/20
2, 3	1	1.75	.63	.75	33	Nickel	Gold	1211-004-N330	A/20
5, 6	2	1.16	.55	.50	07	Nickel	Gold	1211-015-N070	A/17
5, 6	2	1.16	.55	.50	07	Nickel	Gold (C)	1211-015-N071	A/17
7	2	1.16	.55	.50	07	Nickel	Gold	1211-021-N070	A/17
7	2	1.16	.55	.50	07	Nickel	Gold (C)	1211-021-N071	A/17
9	2	1.16	.55	.50	07	Nickel	Gold	1211-036-N070	A/18
9	2	1.16	.55	.50	07	Nickel	Gold (C)	1211-036-N071	A/18
11	2	1.16	.55	.50	07	Nickel	Gold	1211-038-N070	A/18

Heli-Grip for Flexible Cable

5, 6 [§]	1	1.16	.55	.50	07	Nickel	Silver (C)	1211-018-N075-1	E/03
RG-223	1	1.16	.55	.50	07	Nickel	Silver (C)	1211-015-N075	E/03
7	1	1.16	.55	.50	07	Nickel	Silver (C)	1211-019-N075	E/03
8A	1	1.16	.55	.50	07	Nickel	Silver (C)	1211-029-N075	E/03
8B	1	1.16	.55	.50	07	Nickel	Silver (C)	1211-043-N075	E/03
9	1	1.16	.55	.50	07	Nickel	Silver (C)	1211-037-N075	E/03
10	1	1.16	.55	.50	07	Nickel	Silver (C)	1211-100-N075	E/03
11	1	1.16	.55	.50	07	Nickel	Silver (C)	1211-038-N075	E/03

Solder-Clamp for Semi-Rigid Cable

13	1	1.16	.55	.50	07	Nickel*	Gold	1211-031-N073	F/08
14	1	1.16	.55	.50	07	Nickel*	Gold	1211-025-N073	F/07

[§]Except RG-223/U.

* Solder ferrule is gold plated.

(C) in contact plating column indicates captive contact.

Panel Jack Receptacles—Square Flange

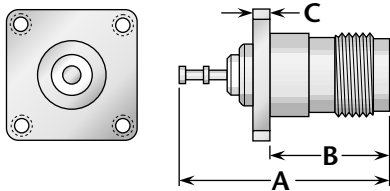

Figure 1
(Turret contact)

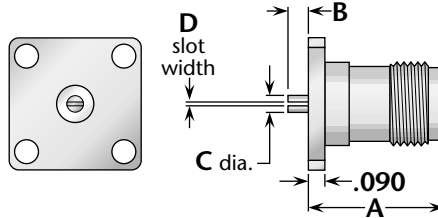

Figure 2
(Slotted contact)

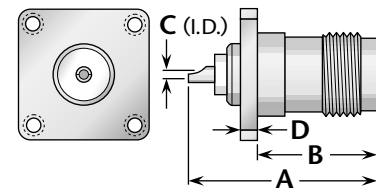

Figure 3
(Solder pot contact)

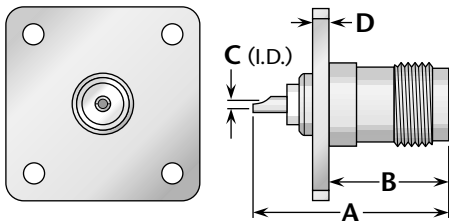

Figure 4
(Solder pot contact, 1" square flange,
interchangeable with type N standard flange size)

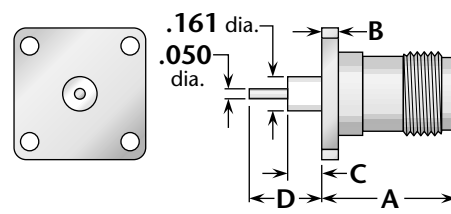

Figure 5
(Post contact)

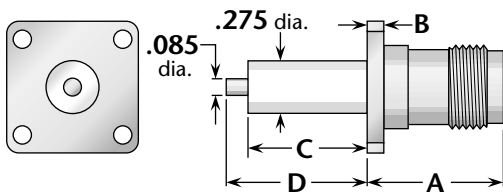

Figure 6
(Post contact)

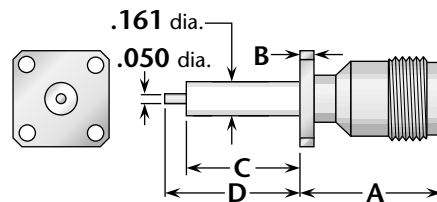

Figure 7
(Post contact, 1/2" square flange,
interchangeable with SMA standard flange size)

Figure	Dimensions				Mounting Figure	Plating		Delta P/N
	A	B	C	D		Body	Contact	
1	1.06	.63	.090	—	07	Nickel	Silver (C)	1212-000-N070
2	.715	.050	.085	.012/.017	09	Nickel	Gold (C)*	1243-000-F09E-1
2	.715	.050	.085	.036/.040	09	Nickel	Gold (C)*	1243-000-F09E-2
3	1.06	.63	.062	.090	07	Nickel	Gold (C)	1213-000-N071
3	1.06	.63	.062	.090	08	Nickel	Gold (C)	1213-000-N080
3	1.06	.63	.062	.090	09	Nickel	Gold (C)	1213-000-N090
3	1.06	.63	.062	.090	18	Nickel	Gold (C)	1213-000-N180
4	1.06	.63	.062	.080	33	Nickel	Gold (C)	1213-000-N330
5	.715	.090	.175	.375	09	Nickel	Gold (C)	1258-000-N091-9
6	.750	.080	.000	1.25	18	Nickel	Gold (C)	1258-000-N181
6	.750	.080	.590	.705	18 ^s	Nickel	Gold (C)*	1258-000-N181-9
7	.750	.080	.590	.705	05	Nickel	Gold (C)	1258-000-N051

(C) in contact plating column indicates captive contact. • *Indicates epoxy-captivated contact.
^sFlange #18 except with .125 dia. mounting holes. • All items are available with other flange sizes and contact configurations.

Right Angle Panel Jack Receptacle—Square Flange

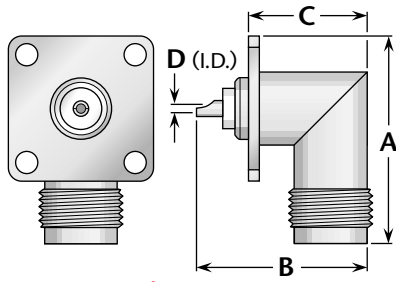

Figure 1
(Solder pot contact)

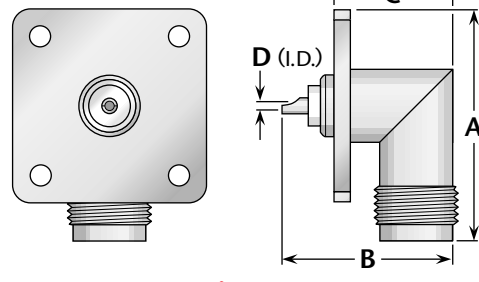

Figure 2
(Solder pot contact, 1" square flange, interchangeable with type N standard flange size)

Figure	Dimensions				Mounting Figure	Plating		Delta P/N
	A	B	C	D		Body	Contact	
1	1.06	.91	.65	.062	07	Nickel	Gold (C)	1215-000-N070
1	1.06	.91	.65	.062	08	Nickel	Gold (C)	1215-000-N080
1	1.09	.91	.61	.062	18	Nickel	Gold (C)	1215-000-N180
2	1.22	.91	.65	.062	33	Nickel	Gold (C)	1215-000-N330

Panel Plug Receptacle—Square Flange

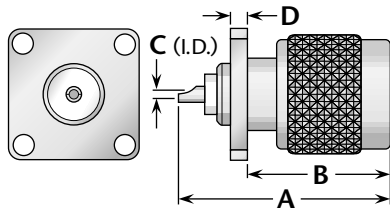

Figure 1
(Solder pot contact, 3/4" square flange)

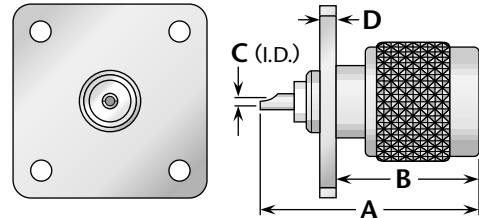

Figure 2
(Solder pot contact, 1" square flange, interchangeable with type N standard flange size)

Figure 3
(Slotted contact, 11/16" square flange)

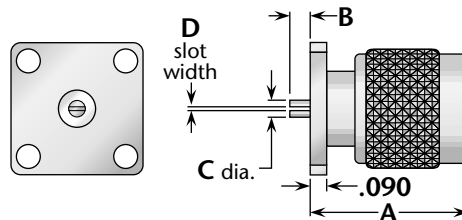

Figure	Dimensions				Mounting Figure	Plating		Delta P/N
	A	B	C	D		Body	Contact	
1	1.16	.72	.062	.090	18	Nickel	Gold (C)	1223-000-N180
2	1.16	.72	.062	.080	33	Nickel	Gold (C)	1223-000-N330
3	.83	.050	.083	.012/.017	09	Nickel	Gold (C)	1259-000-N091-1
3	.83	.050	.083	.030	09	Nickel	Gold (C)	1259-000-N091-2
3	.83	.050	.083	.040	09	Nickel	Gold (C)	1259-000-N091-3

(C) in contact plating column indicates captive contact.

Bulkhead Jack Receptacles

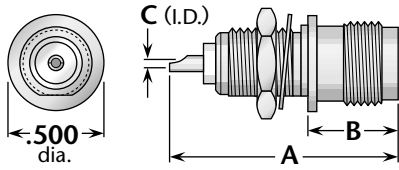

Figure 1
(Front mount)

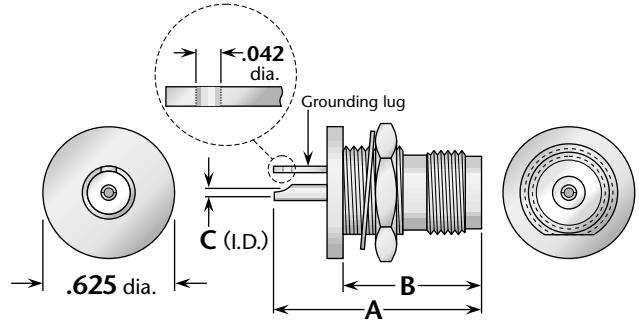

Figure 2
(Rear mount, with grounding lug)

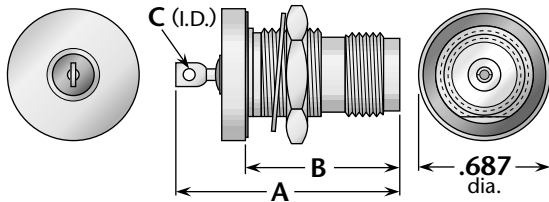

Figure 3
(Rear mount, hermetically sealed,
with mounting gasket)

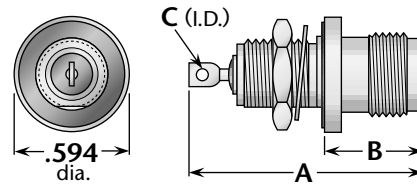

Figure 4
(Front mount, hermetically sealed,
with mounting gasket)

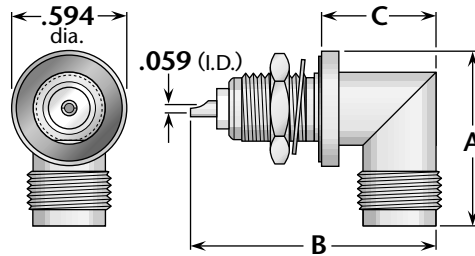
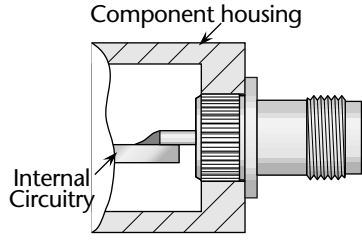

Figure 5
(Right angle, with mounting gasket)

Figure	Dimensions			Max. Panel	Mounting Figure	Plating		Delta P/N
	A	B	C			Body	Contact	
1	1.06	.47	.062	.13	62	Nickel	Gold (C)	1220-000-N620
1	1.19	.47	.062	.26	62	Nickel	Gold (C)	1220-000-N62E-1
1	1.06	.47	.062	.13	65	Nickel	Gold (C)	1220-000-N650
1	1.06	.47	.062	.19	65	Nickel	Silver (C)	1220-000-N656
1	1.06	.47	.062	.19	65	Nickel	Gold (C)	1220-000-N65E
1	1.19	.47	.062	.26	65	Nickel	Gold (C)	1220-000-N65G
2	1.06	.75	.062	.16	59	Nickel	Gold (C)	1221-000-N591-3
3	1.20	.83	.062	.26	59	Nickel	Gold (C)	1221-000-N598
4	1.20	.52	.062	.26	63	Nickel	Gold (C)	1220-000-N638
5	.97	1.22	.59	.13	63	Nickel	Gold (C)	1222-000-N630-1
5	.97	1.34	.59	.25	63	Nickel	Gold (C)	1222-000-N630-2

(C) in contact plating column indicates captive contact.

PressMount Receptacles



Delta PressMount Receptacles

These connectors eliminate the need for complicated mounting hole patterns and mounting hardware. They are simply pressed into a single through hole, and the precisely-engineered knurled mounting section provides retention strength far greater than normal mating and unmating forces. An integral shoulder provides a positive stop when mounting.

PressMounts are available for a wide variety of Delta connector series, and can be used in packages as small as the outer diameter of the connector body.

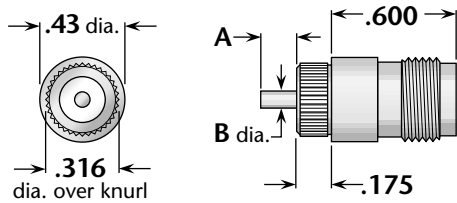

Figure 1
(Post contact)

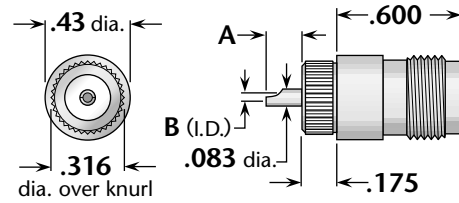

Figure 2
(Solder pot contact)

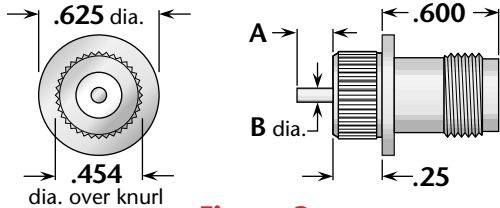

Figure 3
(Post contact)

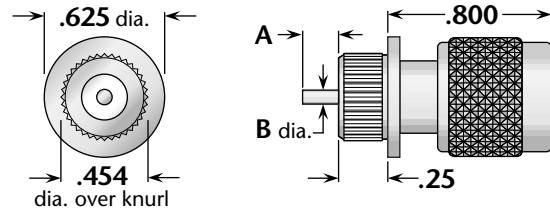

Figure 4
(Plug type, post contact)

Figure	Dimensions		Min. Panel	Mounting Hole	Plating		Delta P/N
	A	B			Body	Contact	
1	.062	.050	.150	.312 ±.001 dia.	Nickel	Gold (C)	1220-000-N911-2
2	.285	.062	.150	.312 ±.001 dia.	Nickel	Gold (C)	1220-000-N911-3
3	.060	.050	.200	.450 ±.001 dia.	Nickel	Gold (C)	1220-000-N911-5
4	.060	.050	.200	.450 ±.001 dia.	Nickel	Gold (C)	1224-000-N911-2

Stripline Receptacles

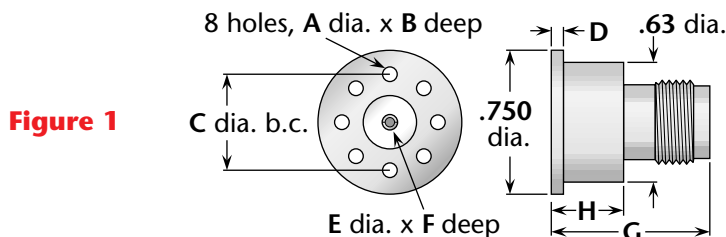

Figure	Dimensions								Plating		Delta P/N
	A	B	C	D	E	F	G	H	Body	Contact	
1	.078	.31	.500	.063	.063	.22	.828	.375	Nickel	Gold (C)	1256-000-N000-2
1	#2-56	.25	.500	.063	.063	.22	.828	.375	Nickel	Gold (C)	1256-000-N000-3

(C) in contact plating column indicates captive contact.

Resistive Termination (Plug Type)

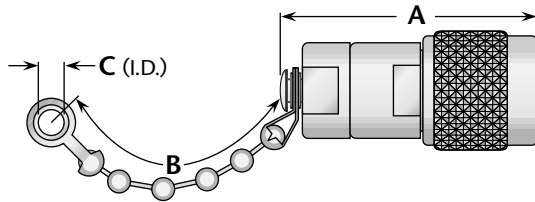

Figure 1

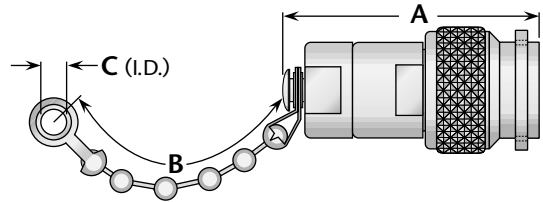

Figure 2

(Safety-wire holes in coupling nut)

Resistor	Fig.	Dimensions			Features	Plating		Delta P/N
		A	B	C		Body	Contact	
51Ω ±5%, 1/2 Watt	1	1.25	3.50	.144	Bead chain	Nickel	Gold (C)	1231-000-N000
51Ω ±5%, 1/2 Watt	1	1.25	—	—	No chain	Nickel	Gold (C)	1231-000-N00A
75Ω ±1%, 1/2 Watt	2	1.25	3.50	.144	Bead chain	Nickel	Gold (C)	1231-000-N000-5
75Ω ±1%, 1/2 Watt	1	1.25	—	—	No chain	Nickel	Gold (C)	1231-000-N00A-2

Dust Caps

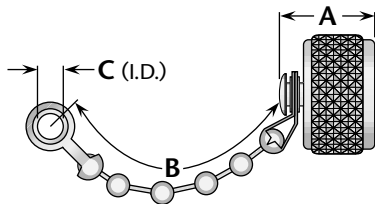

Figure 1

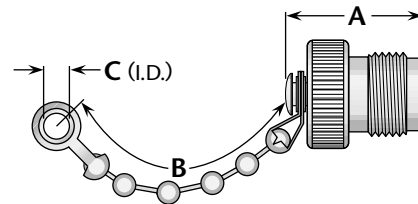
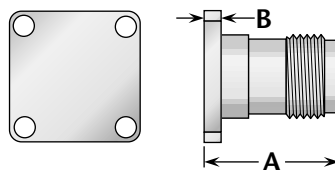

Figure 2

Figure	Dimensions			Features	Plating		Delta P/N
	A	B	C		Body	Contact	
1	.53	2.25	.144	Bead chain	Nickel	—	1232-000-N000
1	.37	—	—	No chain	Nickel	—	1232-000-N00A
1	.69	2.25	.144	Bead chain / shorting type	Nickel	Gold (C)	1232-000-N00C
2	.58	3.50	.144	Bead chain	Nickel	—	1233-000-N000-2
2	.58	—	—	No chain	Nickel	—	1233-000-N00A
2	.69	2.50	.144	Bead chain / shorting type	Nickel	Gold (C)	1233-000-N00C

Dummy Receptacle



Dimensions		Mounting Figure	Plating		Delta P/N
A	B		Body	Contact	
.715	.080	09	Nickel	—	1263-000-N090

(C) in contact plating column indicates captive contact.

Keying Baskets—For Polarization of Mated Pairs

Multiple Polarizations in a Single Installation

In applications with multiple connector pairs, these keying baskets polarize individual jacks so they can only be mated with plugs that have coupling nuts modified with the correct groove orientation.

The grooves in the plug coupling nuts engage the keying bars in the basket, making it impossible to mismatch pairs, even by force.

The keying baskets can be used with any TNC jack—they slide over the jack's mating threads and are secured with a Truarc retaining ring. Any Delta TNC plug can be supplied with a grooved coupling nut to match any keying basket.

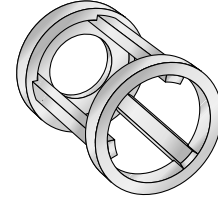

Application Example

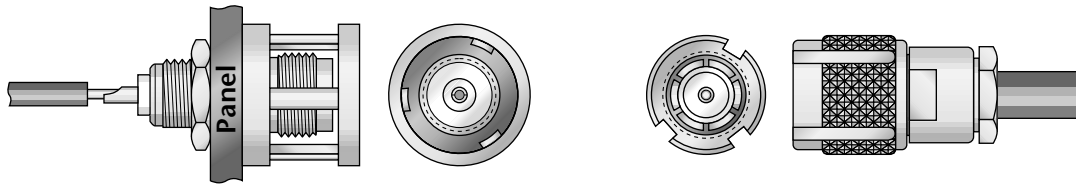

Jack with keying basket installed

Plug with grooved coupling nut

Mated pair

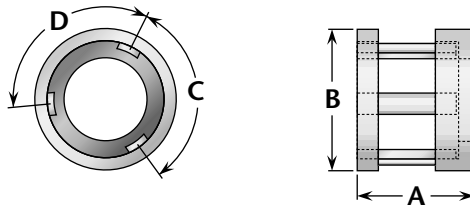

Figure 1

Figure	Dimensions				Plating	Delta P/N
	A	B	C	D		
1	.43	.73	72°	120°	Silver	1261-000-A00M-1
1	.43	.73	96°	96°	Silver	1261-000-A00M-2
1	.43	.73	120°	144°	Silver	1261-000-A00M-3
1	.43	.73	72°	144°	Silver	1261-000-A00M-4
1	.43	.73	120°	120°	Silver	1261-000-A00M-5
1	.43	.73	120°	72°	Silver	1261-000-A00M-6

Bulkhead and Panel Mounted Jack-Jack Adapters (Connect two plugs)

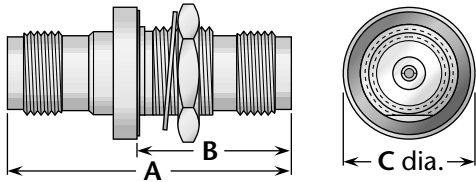

Figure 1
(Bulkhead mount)

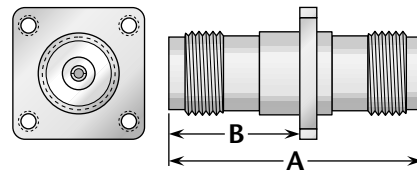

Figure 2
(Panel mount)

Figure	Dimensions			Max. Panel	Mounting Figure	Plating		Delta P/N
	A	B	C			Body	Contact	
1	1.28	.80	.625	.16	59	Nickel	Gold (C)	1226-000-N591-1
1	1.39	.76	.69	.19	59	Nickel	Gold (C)	1226-000-N598-2*
2	1.28	.69	—	—	07	Nickel	Silver (C)	1225-000-N070-1

* Hermetically sealed, with mounting gasket.

Straight Adapters

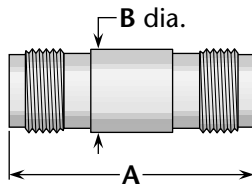

Figure 1
(Straight jack-jack;
connects two plugs)

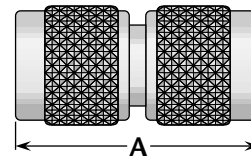

Figure 2
(Straight plug-plug;
connects two jacks)

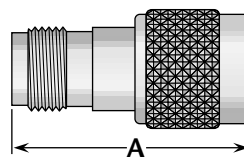

Figure 3
(Straight jack-plug;
connects one plug and one jack)

Figure	Dimensions		Plating		Delta P/N
	A	B	Body	Contact	
1	1.28	.44	Nickel	Silver (C)	1228-000-N000
2	1.25	—	Nickel	Gold (C)	1227-000-N000
3	1.22	—	Nickel	Gold (C)	1234-000-N000

(C) in contact plating column indicates captive contact.

Right Angle Adapters

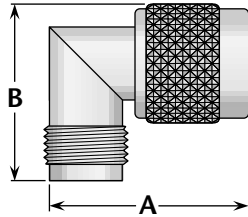

Figure 1
(Right angle plug-jack;
connects one plug and one jack)

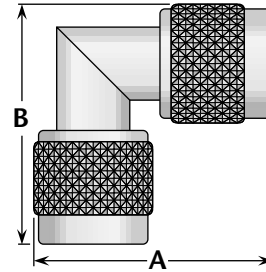

Figure 2
(Right angle plug-plug;
connects two jacks)

Figure	Dimensions		Plating		Delta P/N
	A	B	Body	Contact	
1	1.03	.95	Nickel	Gold (C)	1229-000-N000
2	1.25	1.25	Nickel	Gold (C)	1241-000-N000

Tee Adapters

Figure 1
(Tee jack-jack-jack;
connects three plugs)

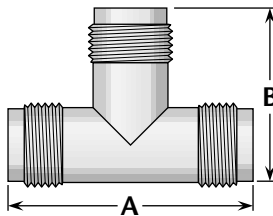

Figure 2
(Tee jack-plug-jack;
connects two plugs
and one jack)

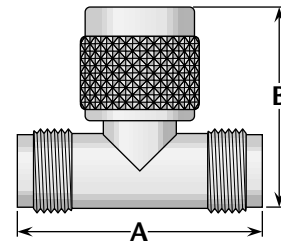

Figure 3
(Tee plug-jack-plug;
connects two jacks
and one plug)

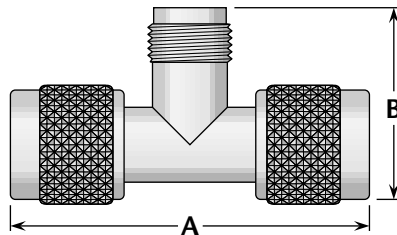

Figure 4
(Tee jack-jack-plug;
connects two plugs
and one jack)

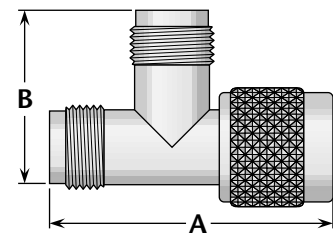

Figure	Dimensions		Plating		Delta P/N
	A	B	Body	Contact	
1	1.28	.88	Nickel	Gold (C)	1238-000-N000
2	1.28	1.03	Nickel	Gold (C)	1230-000-N000
3	1.88	.95	Nickel	Gold (C)	1242-000-N000
4	1.48	1.06	Nickel	Silver (C)	1249-000-N000

(C) in contact plating column indicates captive contact.

Cable Plugs and Jacks

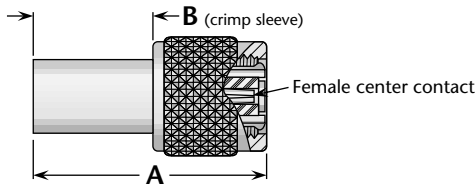

Figure 1
(Crimp type plug)

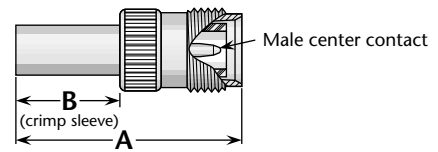

Figure 2
(Crimp type jack)

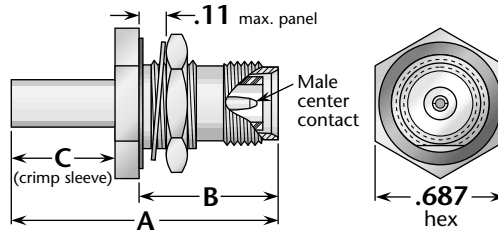

Figure 3
(Crimp type bulkhead jack)

Cable Group	Fig.	Dimensions			Mounting Figure	Plating		Delta P/N	Assembly Procedure/Trim Code
		A	B	C		Body	Contact		
5	1	1.06	.50	—	—	Nickel	Gold	1203-017-N002	B/23
5	2	1.16	.50	—	—	Nickel	Gold	1210-017-N002	B/05
5	3	1.31	.68	.50	59	Nickel	Gold	1219-017-N592	B/13
6	1	1.06	.50	—	—	Nickel	Gold	1203-013-N002	B/23
6	2	1.16	.50	—	—	Nickel	Gold	1210-013-N002	B/05
6	3	1.31	.68	.50	59	Nickel	Gold	1219-013-N592	B/13

Jack Receptacles

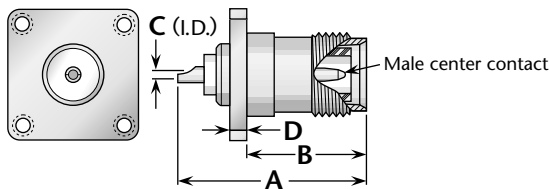

Figure 1
(Panel jack receptacle)

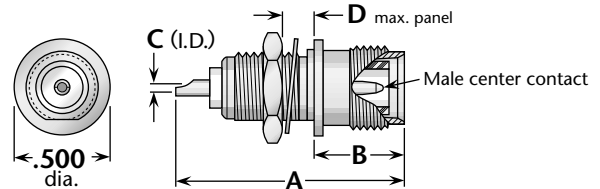
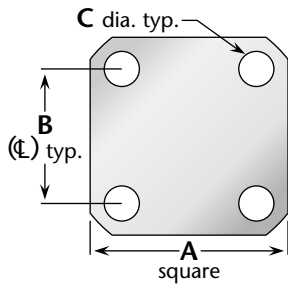

Figure 2
(Bulkhead jack receptacle)

Figure	Dimensions				Mounting Figure	Plating		Delta P/N
	A	B	C	D		Body	Contact	
1	1.06	.63	.062	.090	07	Nickel	Gold (C)	1213-000-N072-5
1	1.16	.63	.062	.090	09	Nickel	Gold (C)	1213-000-N092
2	1.06	.47	.062	.13	62	Nickel	Gold (C)	1220-000-N622
2	1.06	.47	.062	.19	65	Nickel	Gold (C)	1220-000-N652-1

(C) in contact plating column indicates captive contact.

Connector Flanges (Panel mounted connectors)



4-hole flanges

Figure	A	B	C
04	1/2	.360	.089
05	1/2	.340	.102
07	11/16	.500	#3-56 tap
08	11/16	.500	.136
09	11/16	.500	.125
10	11/16	.500	.120
12	11/16	.500	.109
18	3/4	.531	.136
26	1	.718	#6-32 tap
27	1	.718	#4-40 tap
30	1	.718	.166
32	1	.718	.136
32A	1	.718	.136*
33	1	.718	.125
34	13/32	.812	.150
36	13/16	.906	#6-32 tap
39	13/16	.906	.152
40	13/16	.906	.125
45	2	1.437	.257
91	.375	.250	.067
91A	.375	.232	.093

* Countersunk to .245 dia.

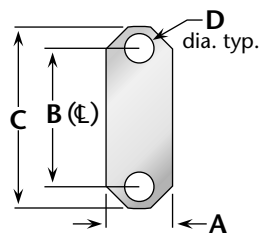

2-hole flanges

Figure	A	B	C	D
92	.223	.481	.625	.102
92A	.260	.481	.625	.102
95	.640	1.015	1.30	.125

Panel Cutouts (Bulkhead mounted connectors)

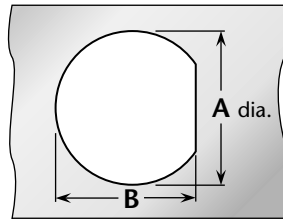

D-Hole

Figure	A	B
51	.755	.723
54	.630	.598
55	.630	.583
57	.557	.531
59	.505	.473
62	.442	.410
63	.407	.362
65	.380	.348
66	.319	.292
67	.255	.236
68	.195	.176

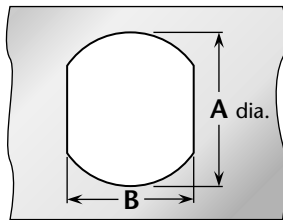

Double D-Hole

Figure	A	B
69	.755	.692
72	.630	.536
75	.380	.341
84	.319	.278

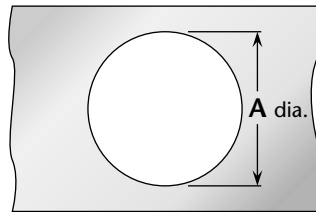

Round Hole

Figure	A
82	.255
89	.380

P.C. Board Drilling

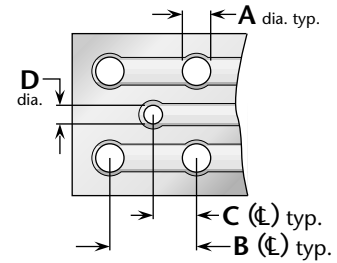

(PCB traces are shown for illustrative purpose only, and are not representative of actual circuitry.)

Coaxial connectors

Figure	A	B	C	D
PCB01	.067	.400	.200	.045
PCB02	.045	.500	.250	.045
PCB03	.067	.300	.150	.035
PCB05	.067	.200	.100	.055
PCB06	.067	.200	.100	.045
PCB07	.045	.177	.088	.045
PCB08	.032	.100	.050	.032

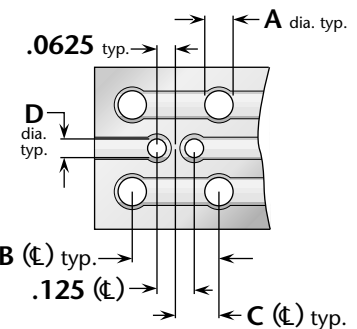

(PCB traces are shown for illustrative purpose only, and are not representative of actual circuitry.)

Twinax connectors

Figure	A	B	C	D
PCB04	.045	.500	.250	.045

Cable Group Finder			
Cable	Group	Cable	Group
RG-5, 5A, B	1A	RG-225	3C
RG-6, 6A	1B	RG-228A	20
RG-8, 8A	2A	RG-302	22
RG-9, 9A, B	3A	RG-303	23
RG-10	15	RG-304	24
RG-11, 11A	2B	RG-316	9A
RG-12	15	RG-316DS	10
RG-13A	3B	RG-393	4
RG-14A	16	RG-400	6A
RG-17A	17	RG-401	12
RG-18A	18	RG-402	13
RG-21, 21A	1A	RG-405	14
RG-22, 22A, B	28	M17/2	1B
RG-55, 55B	6B	M17/6	2B
RG-55A	6A	M17/15	28
RG-58, 58A, C	5	M17/28	5
RG-59, 59A, B	7A	M17/29	7A
RG-62, 62A, B, C	7A	M17/30	7A
RG-71, 71A, B	7B	M17/45	27
RG-108, 108A	27	M17/73	1A
RG-115A	19	M17/162	1A
RG-118A	20	M17/112	1C
RG-122	8A	M17/74	2A
RG-126	21	M17/75	3A
RG-141, 141A	5	M17/127	3C
RG-142, 142A	6A	M17/77	3B
RG-142B	6B	M17/60	6A
RG-143, 143A	1C	M18/84	6A
RG-174	9A	M17/128	6A
RG-174DS	10	M17/97	7A
RG-178, 178A, B	11	M17/54	8A
RG-179A, 179B	9B	M17/95	8B
RG-180, 180A, B	8B	M17/137	8B
RG-187, 187A	9B	M17/152	9A
RG-188, 188A	9A	M17/93	11
RG-195	8B	M17/129	12
RG-196, 196A	11	M17/130	13
RG-210	7A	M17/133	14
RG-212	1C	M17/78	16
RG-213	2A	M17/165	16
RG-214	3A	M17/176	30
RG-215	15	AT&T 735A	31
RG-217	16	Belden 8281	26
RG-218	17	Belden 9207	29
RG-219	18	Dearborn 6207	29
RG-222	1C	IBM 7362211	29
RG-223	6A		

Delta Cable Groups	
Group	Cables
1	1A RG-5, 5A, 5B, 21, 21A; M17/73, /162
	1B RG-6, 6A; M17/2
	1C RG-143, 143A, 212, 222; M17/73, /112, /162
2	2A RG-8, 8A, 213; M17/74
	2B RG-11, 11A; M17/6
3	3A RG-9, 9A, 9B, 214; M17/75
	3B RG-13A, 216; M17/77
	3C RG-225; M17/127
4	RG-393; M17/127
5	RG-58, 58A, 58C, 141, 141A; M17/28, /111
6	6A RG-55A, 142, 142A, 223, 400; M17/60, /84, /128
	6B RG-55, 55B, 142B; M17/60, /84
7	7A RG-59, 59A, 59B, 62, 62A, 62B, 62C, 210; M17/29, /30, /97
	7B RG-71, 71A, 71B; M17/90
8	8A RG-122; M17/54
	8B RG-180, 180A, 180B, 195; M17/95, /137
9	9A RG-174, 188, 188A, 316; M17/152
	9B RG-179A, 179B, 187, 187A; M17/94, /136
10	Double-Shielded RG-174, 316; M17/152
11	RG-178, 178A, 178B, 196, 196A; M17/93
12	.250" semi-rigid; RG-401; M17/129
13	.141" semi-rigid; RG-402; M17/130
14	.085" semi-rigid; RG-405; M17/133
15	RG-10, 12, 215; M17/6, /74
16	RG-14A, 217; M17/78, /165
17	RG-17A, 218
18	RG-18A, 219
19	RG-115A
20	RG-118A, 228A
21	RG-126
22	RG-302
23	RG-303
24	RG-304
25	Special 8X cable; contact factory for details.
26	Belden 8281
27	RG-108, 108A; M17/45
28	RG-22, 22A, 22B; M17/15
29	Belden 9207; Dearborn 6207; IBM 7362211
30	M17/176
31	AT&T 735A

Assembly Procedure A

- 1)** Trim cable jacket to dimension A. Slide backnut, washer, V-gasket, and braid clamp onto cable as shown. Cable jacket should bottom on step in braid clamp.

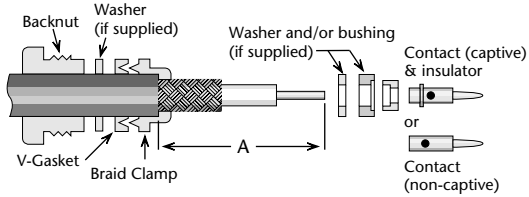

- 2)** Comb braid wires out straight and fold back over front shoulder of braid clamp (braid wires should not overlap one another after folding). Trim braid wires flush with step of braid clamp. Trim cable dielectric and center conductor to dimensions B and C.

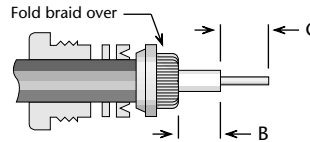

- 3)** If support insulator is provided for RG-62 or 71 cable, insert into hollow in dielectric. Assemble rear bushing or washer (if supplied), rear insulator (if captive contact) and contact, and solder contact to center conductor. Rear of contact should be flush with cable dielectric end. For right angle connectors with access cap, omit this step entirely.

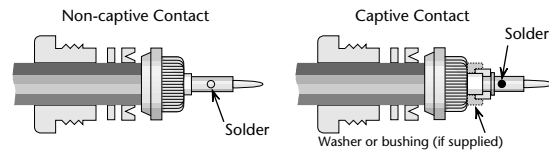

- 4)** Insert prepared cable and hardware into body and tighten backnut. For right angle connectors with access cap, solder center conductor into slot in contact and tighten access cap.

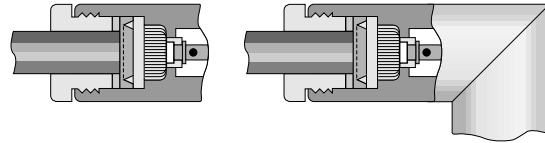

Trim Codes For Assembly Procedure A

Code	A	B	C	Code	A	B	C
A/01	.375 (3/8)	.047 (3/64)	.203 (13/64)	A/20	.375 (3/8)	.047 (3/64)	.172 (11/64)
A/02	.375 (3/8)	.109 (7/64)	.203 (13/64)	A/21	.500 (1/2)	.313 (5/16)	.172 (11/64)
A/03	.438 (7/16)	.250 (1/4)	.188 (3/16)	A/22	.375 (3/8)	.188 (3/16)	.141 (9/64)
A/04	.281 (9/32)	.047 (3/64)	.125 (1/8)	A/23	.438 (7/16)	.078 (5/64)	.172 (11/64)
A/05	.313 (5/16)	.125 (1/8)	.109 (7/64)	A/24	.500 (1/2)	.094 (3/32)	.141 (9/64)
A/06	.594 (19/32)	.391 (25/64)	.156 (5/32)	A/25	.438 (7/16)	.141 (9/64)	.172 (11/64)
A/07	.375 (3/8)	.047 (3/64)	.125 (1/8)	A/26	.625 (5/8)	.281 (9/32)	.250 (1/4)
A/08	.281 (9/32)	.109 (7/64)	.094 (3/32)	A/27	.688 (11/16)	.281 (9/32)	.125 (1/8)
A/09	.344 (11/32)	.109 (7/64)	.094 (3/32)	A/28	.656 (21/32)	.297 (19/64)	.250 (1/4)
A/10	.406 (13/32)	.109 (7/64)	.203 (13/64)	A/29	.688 (11/16)	.125 (1/8)	.313 (5/16)
A/11	.500 (1/2)	.281 (9/32)	.156 (5/32)	A/30	.688 (11/16)	.469 (15/32)	.156 (5/32)
A/12	.343	.040	.219	A/31	.700 (21/32)	.453 (29/64)	.250 (1/4)
A/13	.375 (3/8)	.125 (1/8)	.156 (5/32)	A/32	.313 (5/16)	.078 (5/64)	.188 (3/16)
A/14	.355	.090	.188 (3/16)	A/33	.250 (1/4)	.078 (5/64)	.094 (3/32)
A/15	.425	.094 (3/32)	.259	A/34	.250 (1/4)	.062 (1/16)	.109 (7/64)
A/16	.328 (21/64)	.094 (3/32)	.188 (3/16)	A/35	.837	.575	.150
A/17	.375 (3/8)	.109 (7/64)	.125 (1/8)	A/36	.450	.250	.150
A/18	.375 (3/8)	.062 (1/16)	.172 (11/64)	A/37	.281	.038	.188
A/19	.375 (3/8)	.188 (3/16)	.094 (3/32)	A/38	.281	.069	.156

Assembly Procedure B

- 1) Trim cable per chart. Slide crimp sleeve back onto cable.

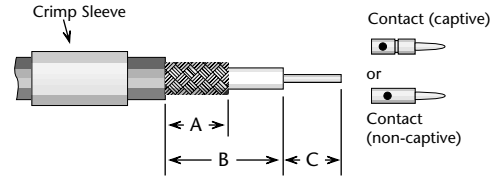

- 2) If support insulator is provided for RG-62 or 71 cable, insert into hollow in dielectric. Solder contact onto center conductor; back of contact flush with trimmed end of cable dielectric (omit this step for right angle connectors with access caps). Flare cut end of braid slightly by rotating dielectric.



- 3) Insert cable/contact into rear of body, with all braid wires on outside of crimp tail.
- For captive contact connectors, push cable in until contact snaps into insulator.
 - For noncaptive contact connectors, push cable in until cable dielectric bottoms in connector.
 - For right angle or tee connectors with access caps, push cable in until end of braid touches connector body shoulder, and cable center conductor rests in contact slot.

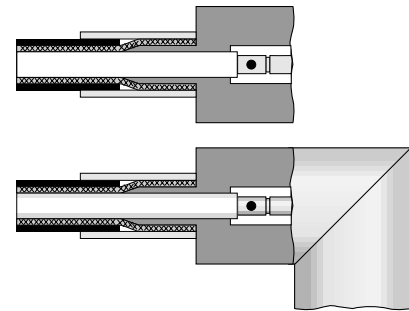

Trim excess braid wires even with shoulder of body. Slide crimp sleeve forward until flush with body and crimp (see page 176 for hex die sizes).

For right angle or tee connectors with access caps: Solder center conductor into contact slot, assemble insulator disc (if supplied), then press cap into body until seated or screw into place.

Trim Codes For Assembly Procedure B

Code	A	B	C	Code	A	B	C
B/01	.320	.470	.140	B/20	.250	.375	.156
B/02	.422	.578	.172	B/21	.425	.550	.156
B/03	.406	.500	.187	B/22	.375	.500	.156
B/04	.285	.505	.140	B/23	.281	.469	.125
B/05	.335	.460	.140	B/24	.250	.700	.109
B/06	.187	.437	.219	B/25	.343	.775	.125
B/07	.422	.610	.156	B/26	.343	.437	.109
B/08	.422	.562	.219	B/27	.313	.437	.187
B/09	.313	.610	.203	B/28	.219	.271	.078
B/10	.280	.436	.187	B/29	.200	.320	.060
B/11	.430	.542	.156	B/30	.500	.650	.219
B/12	.300	.434	.156	B/31	.350	.840	.150
B/13	.300	.447	.156	B/32	.175	.260	.095
B/14	.420	.645	.187	B/33	.195	.270	.045
B/15	.300	.420	.120	B/34	.150	.250	.105
B/16	.312	.609	.125	B/35	.195	.280	.170
B/17	.250	.500	.156	B/36	.150	.325	.090
B/18	.437	.562	.109	B/37	.195	.295	.075
B/19	.343	.437	.156	B/38	.150	.225	.095
				B/39	.250	.300	.135

Assembly Procedure E

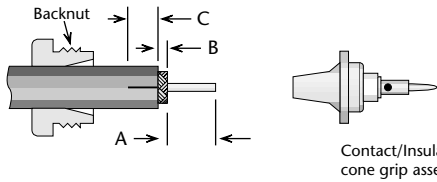

1) Slide backnut onto cable as shown. Trim cable to dimensions A and B as shown. Slit jacket to dimension C in two places, 180° apart.

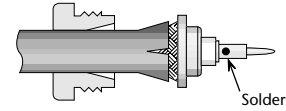

2) Slide cone/insulator/contact assembly under braid until braid is flush with shoulder. Solder contact to center conductor.

Trim Codes			
Code	A	B	C
E/01	.250 (1/4)	.141 (9/64)	.313 (5/16)
E/02	.219 (7/32)	.063 (1/16)	.250 (1/4)
E/03	.250 (1/4)	.031 (1/32)	.250 (1/4)

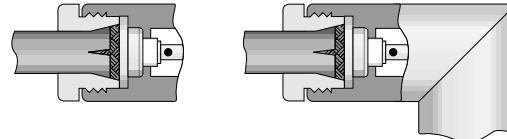

3) Insert prepared cable and hardware into body; tighten assembly by holding nut stationary and turning body.

Assembly Procedure F

Trim Codes		
Code	A	B
F/01	.250 (1/4)	.219 (7/32)
F/02	.250 (1/4)	.172 (11/64)
F/03	.188 (3/16)	.188 (3/16)
F/04	.109 (7/64)	.265 (17/64)
F/05	.156 (5/32)	.250 (1/4)
F/06	.219 (7/32)	.250 (1/4)
F/07	.156 (5/32)	.172 (11/64)
F/08	.109 (7/64)	.219 (7/32)

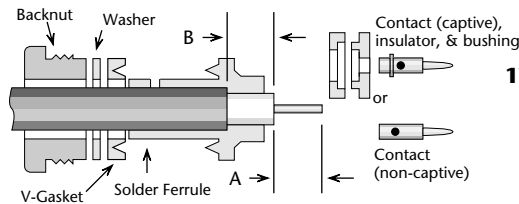

1) Trim cable per chart. Slide backnut, washer, v-gasket, and solder ferrule onto cable. Trimmed end of cable jacket should bottom on step in solder ferrule.

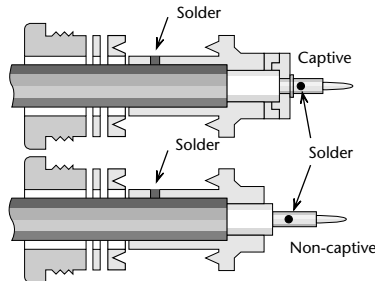

2) Solder ferrule to cable jacket as shown. Retrim cable dielectric to proper length if it has extruded from soldering heat. Slide bushing and rear insulator over cable dielectric if captive contact. Solder contact onto center conductor; back of contact flush with trimmed end of cable dielectric.

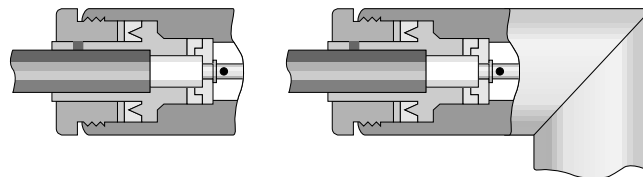

3) Insert prepared cable and hardware into body and tighten backnut.

Crimp Tools for Flexible Cable

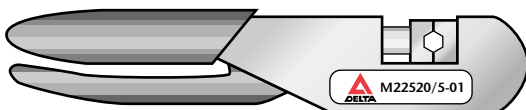

Frame only—P/N M22520/5-01—
Use with interchangeable dies listed below.

Cable Group(s)	Hex Die Size	Die Set P/N	Closure
2, 3, 4	.429 hex, .400 wide	M22520/5-61	A
5, 6	.213 hex, .400 wide	M22520/5-19	B
7	.255 hex, .400 wide	M22520/5-19	A



Warranty

We warrant our parts to be free from defects in materials and workmanship for one year from date of purchase. During that time, we will repair or replace (at our option) any parts found to be defective.

This warranty does not apply to parts which have been modified, used in conditions exceeding Delta or military specifications, or disassembled. We will not, under any circumstances, be responsible for consequential or incidental damages or installation costs.

No other warranties apply, and no other liability may be assumed or extended by representatives or distributors.

Returns

Returns will be accepted only with a Return Authorization number issued by Delta, and are subject to inspection and acceptance upon arrival. Restocking charges will be determined prior to issuance of Return Authorization.

All claims for shortages must be made within 30 days of receipt by customer.

Ordering Information

Orders are subject to the terms and conditions on our order acknowledgement, which may only be modified by written agreement prior to sale. Order changes, cancellation, or termination will be accepted only with written approval from Delta Electronics Manufacturing.

Copyright, Trademarks, and Patents

Entire contents copyright 2003, Delta Electronics Manufacturing Corporation. Reproduction rights are hereby granted for, and specifically limited to, printing or other reproduction of drawings and specifications for inclusion in specification or source control drawings, or for purchasing procedures, by Delta customers only.

Heli-Grip, *PressMount*, and the New England Craftsmanship logo are trademarks. The Heli-Grip design is covered by U.S. and foreign patents.

Delta Electronics Manufacturing Corporation
416 Cabot Street, P.O. Box 53
Beverly, MA 01915
FSCM/CAGE 00795

Catalog # TNCpdf 1.2 (7/09)