

REVISIONS LIST				
REV	ECO #	DESCRIPTION	DATE	APV'D
A		Initial Release		

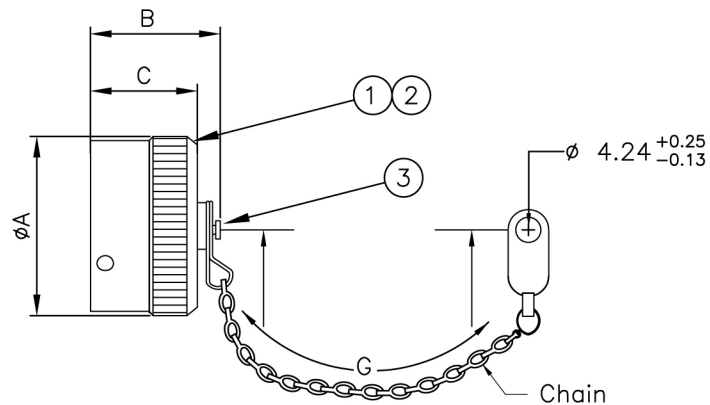

Attachment Option "C"

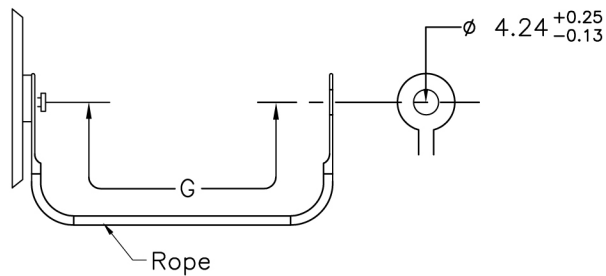

Attachment Option "R"

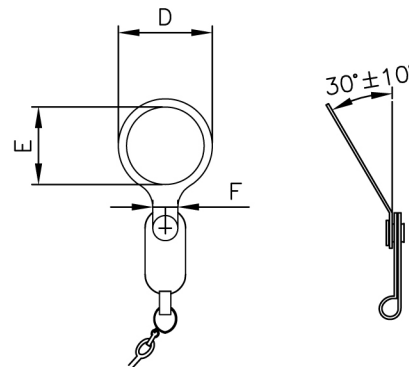

Attachment Option "N"

Shell Size	øA MAX	B MAX	C MAX	D MAX	E MIN	F MIN	G +12.7 / -6.35
8	18.64	21.44	14.27	22.62	14.68	5.94	76.20
10	21.82	21.44	14.27	25.40	17.86	5.94	76.20
12	25.40	21.44	14.27	30.18	22.63	5.94	88.90
14	28.58	21.44	14.27	36.53	25.81	5.94	88.90
16	31.75	21.44	14.27	39.67	28.98	5.94	88.90
18	34.92	21.44	14.27	42.88	32.16	5.94	88.90
20	38.10	21.44	14.27	46.02	35.33	5.94	101.60
22	41.28	21.44	14.27	49.23	38.51	5.94	101.60
24	44.45	22.22	15.29	52.37	41.68	5.94	101.60

No.	Name	Material/Finish	Remarks
1	Shell	Aluminum	
2	Seal	Silicone Rubber	
3	Fatener	Stainless Steel	
	Rope	7 Strand Stainless Steel	
	Chain	Stainless Steel	
	Ring	Stainless Steel	

UNLESS NOTED TOLERANCES ARE:  
.X ± 0.38  
.XX ± 0.25  
ANGLES ± 1°

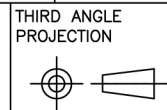

1170 S. PATTON ST.  
XENIA, OHIO 45385  
PH: (937) 374-2700  
FX: (937) 374-2717

UNIT: mm	DRWN: RLM	THESE DRAWINGS AND SPECIFICATIONS ARE THE PROPERTY OF SPI AND SHALL NOT BE COPIED, USED OR RE-PRODUCED WITHOUT PERMISSION.	TITLE	
SCALE: NTS	DATE: 01/18/13		26482 Receptacle Protective Cover	
	CHK'D: TRH		S P I P / N : MS3181-XXXXX	
SHEET: 1 OF 1	APV'D: TRH		C U S T O M E R P / N : MS3181-XXXXX	
			REV: A	