

REVISIONS LIST				
REV	ECO #	DESCRIPTION	DATE	APV'D
A		Initial Release		

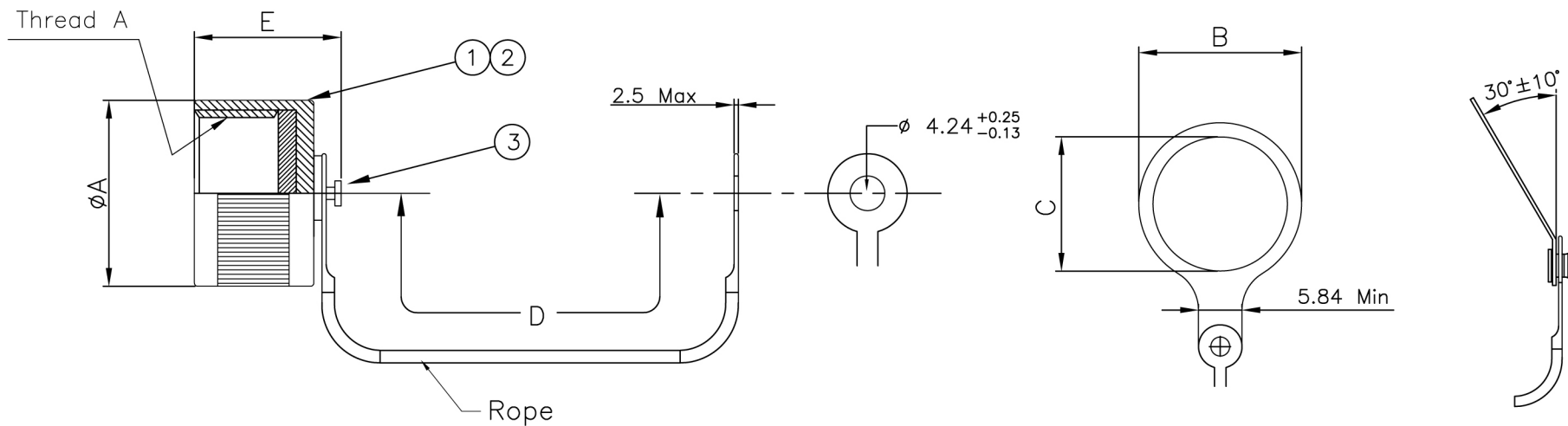

Style "R"

Style "N"

Shell Size	øA MAX	B Max	C Min	D +13.0/-7.0	E Max	Thread "A" -2B (In Inches)
9	23.0	27.0	17.64	127.00	23.0	.6250-0.1P-0.3L-TS
11	28.0	32.0	21.97	127.00	23.0	.7500-0.1P-0.3L-TS
13	31.0	37.0	25.12	127.00	23.0	.8750-0.1P-0.3L-TS
15	32.0	40.0	29.92	127.00	23.0	1.0000-0.1P-0.3L-TS
17	37.0	44.0	32.00	127.00	23.0	1.1875-0.1P-0.3L-TS
19	39.0	46.0	36.27	127.00	23.0	1.2500-0.1P-0.3L-TS
21	42.0	49.0	38.25	127.00	23.0	1.3750-0.1P-0.3L-TS
23	45.0	54.0	42.62	127.00	23.0	1.5000-0.1P-0.3L-TS
25	49.0	56.9	44.45	127.00	23.0	1.6250-0.1P-0.3L-TS

No.	Name	Material/Finish	Remarks
1	Shell	Aluminum	
2	Seal	Silicone Rubber	
3	Fatener	Stainless Steel	
	Rope	7 Strand Stainless Steel	
	Ring	Stainless Steel	

UNLESS NOTED TOLERANCES ARE:

.X ± 0.38
.XX ± 0.25
ANGLES ± 1°

THIRD ANGLE PROJECTION

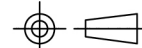

1170 S. PATTON ST.
XENIA, OHIO 45385
PH: (937) 374-2700
FX: (937) 374-2717

UNIT: mm	DRWN: RLM
SCALE: NTS	DATE: 03/19/13
	CHK'D: TRH
SHEET: 1 OF 1	APV'D: TRH

THESE DRAWINGS AND SPECIFICATIONS ARE THE PROPERTY OF SPI AND SHALL NOT BE COPIED, USED OR REPRODUCED WITHOUT PERMISSION.

TITLE
38999 Series III Receptacle Protective Cover

SPIP/N: D38999/33XXXX	REV: A
CUSTOMER P/N: D38999/33XXXX	